

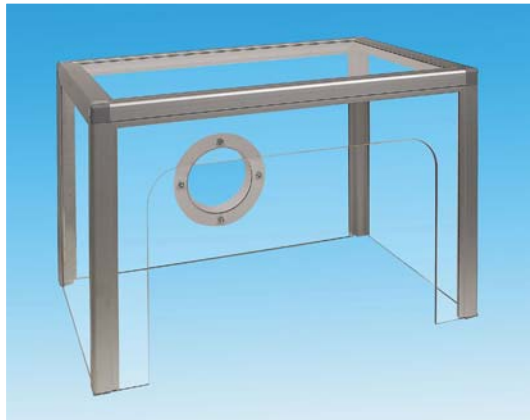

CAPT-AIR®

8001 Rue Larrey, Anjou, QC, Canada, H1J 2L4
514-273-4331 • info@capt-air.com • www.capt-air.com

FUME CABINET



DSK **400, 700**

Fume cabinets for environments where maximum suction efficiency is required.

Fume cabinet for work with open chemical vessels, setup of chemical apparatus, gluing, etc. where several sources of contamination are present.

MOVEX fume cabinets are manufactured with transparent sheets and stable aluminum framing, and thus do not block the work area. It is also easy to move when tasks and locations vary.

The DSK 400 and DSK 700 are produced in two standard sizes. Please contact MOVEX for alternative dimensions and special adaptations.

Movex also offers a range of fans, accessories and automatic control devices for our local extractors.

MOVEX®
LOCAL EXTRACTOR

Pure advantage

DSK-400

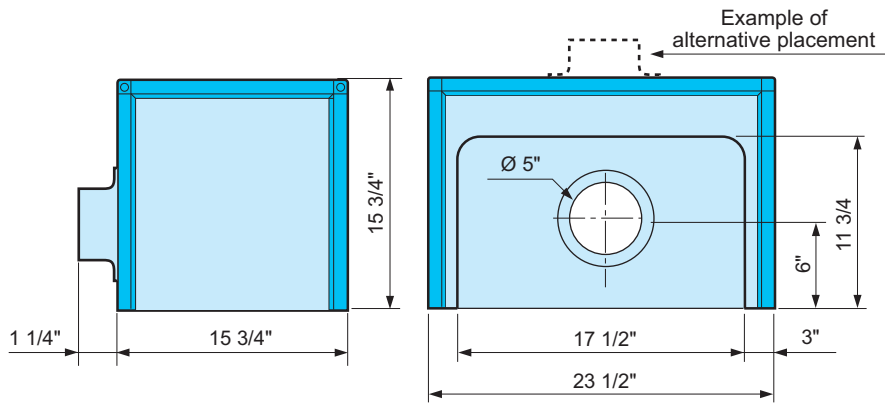

DSK-700

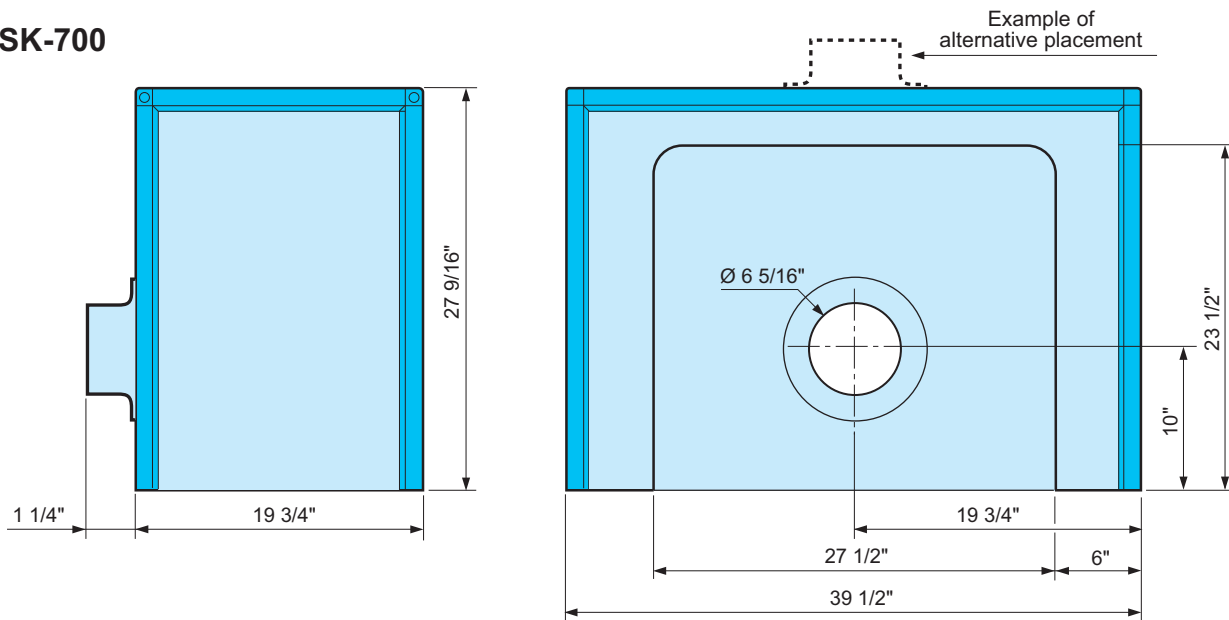

Material

3/16" Vivak PETG sheets
Anodized aluminum frame

Extractor

Connected to separate fan or mobile filter type LF 70.

Standard configuration

Fume cabinet delivered partially assembled.
Exhaust air connection mounted at rear. For alternative placement, specify when ordering.

DSK-400

Airflow
- at 100 F/m front velocity..... 140 Cfm (67 l/s)
- at 60 F/m front velocity 85 Cfm (40 l/s)
Connection size Ø 5"
Volume 25.3 gallon
Weight 14 lb

DSK-700

Airflow
- at 100 F/m front velocity..... 440 Cfm (208 l/s)
- at 60 F/m front velocity 265 Cfm (125 l/s)
Connection size Ø 6"
Volume 92.5 gallon
Weight 30 lb

MOVEX[®] INC.

104 Commerce Drive, Suit C,
Northampton, PA 18067, USA
Tel: 610-440-0478 Fax: 610-440-0480
www.movexinc.com e-mail: info@movexinc.com

Dealer: