



**CAPT-AIR®**

8001 Rue Larrey, Anjou, QC, Canada, H1J 2L4  
514-273-4331 • info@capt-air.com • www.capt-air.com



**IEP TECHNOLOGIES**  
HOERBIGER Safety Solutions



# Explosion Venting Solutions By IEP Technologies

**Since 1956**

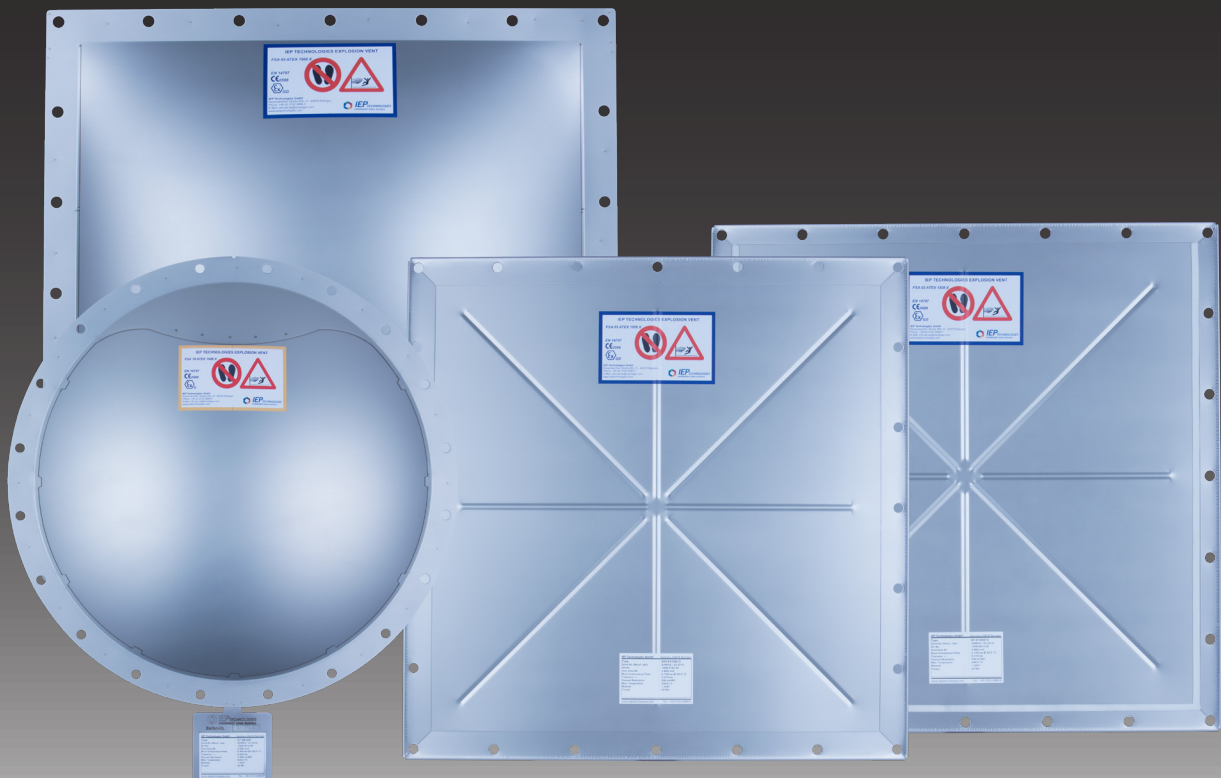

# Explosion Venting

Limiting the destructive effects of a dust explosion within an industrial process is the goal of a comprehensive safety strategy. One of the most cost effective and proven methods to do so is by using rupture-style explosion venting when the application is suited. When an explosion vent activates, it essentially creates an opening in the process equipment to release the deflagration overpressure and fireball to reduce the residual pressure in the equipment to a safe level.

The diagram below shows the pressure development of an explosion in a closed vessel, reaching peak pressures ( $P_{max}$ ) of up to 10 barg, which easily can destroy most process vessels. An IEP Technologies Explosion Vent ruptures at a predetermined pressure ( $P_{stat}$ ) and allows the fireball and destructive pressure to vent to a safe area. The goal of explosion venting is to keep the maximum reduced pressure ( $P_{red,max}$ ) below the vessel strength.

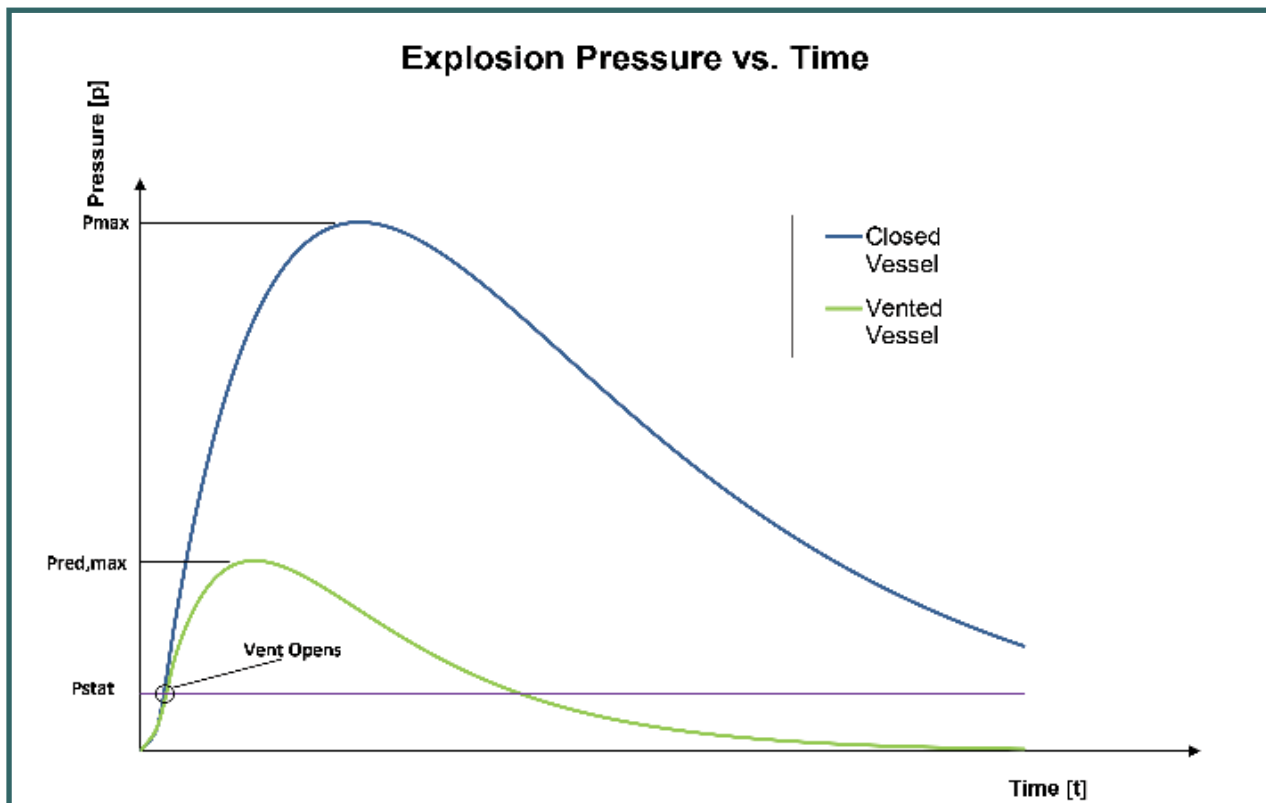

Rupture style vents are economical to install and these highly efficient vents fit into the walls of a process volume. They are available in a variety of sizes, configurations and materials to ensure fast reliable operation during an explosion event.

Explosion venting is a very cost effective option to limit the destructive overpressure from an explosion however it may be just one component of a comprehensive explosion protection solution. Proper review and design of a comprehensive protection solution will also include suitable isolation methods if required. Our protection specialists are available to support you with your specific application.





# Explosion Vent GE

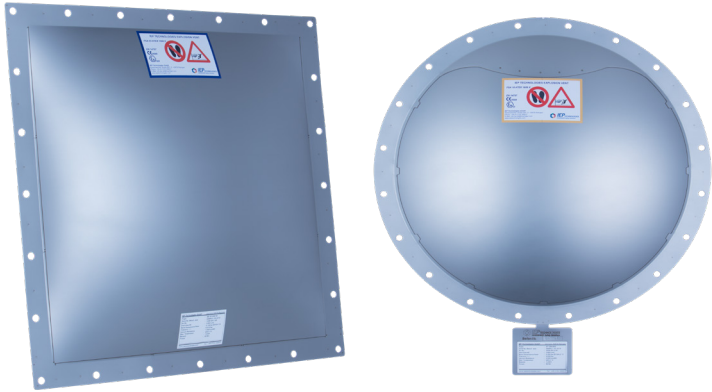

Filter installations with pneumatic cleaning systems and a very high vacuum operation require an explosion vent that withstands vacuum and positive pressure cycling for a long time. For such requirements the GE is the best choice. Its domed design enables negative pressure resistance without the need for an extra vacuum support. The GE type vents feature pressure peak damping as well as integrated flange gaskets.

## GE Round

Millimeters			Inches	
DN	Inside Diam	Outside Diam	Inside Diam	Outside Diam
200	208	268	8.19	10.55
250	261	341	10.28	13.43
300	310	390	12.20	15.35
350	342	422	13.46	16.61
400	393	473	15.47	18.62
450	465	545	18.31	21.46
500	494	574	19.45	22.60
600	596	676	23.46	26.61
24"	610	705	24	27.76
700	696	776	27.40	30.55
750	762	842	30	33.15
30"	768	870	30.25	34.25
800	797	877	31.38	34.53
900	894	974	35.20	38.35
36"	914	1009	36	39.72
1000	995	1075	39.17	42.32
1100	1124	1214	44.25	47.80

**\*\*Chart details standard size vents. Contact IEP for any custom requirements\*\***

# GE Rectangular

Millimeters				Inches			
Inside		Outside		Inside		Outside	
Length	Width	Length	Width	Length	Width	Length	Width
229	229	309	309	9.02	9.02	12.17	12.17
205	290	285	370	8.07	11.42	11.22	14.57
229	305	309	385	9.02	12.01	12.17	15.16
150	600	230	680	5.91	23.62	9.06	26.77
200	460	280	540	7.87	18.11	11.02	21.26
220	420	300	500	8.66	16.54	11.81	19.69
340	385	400	445	13.39	15.16	15.75	17.52
305	457	381	534	12	18	15	21
247	610	327	690	9.72	24.02	12.87	27.17
340	440	400	500	13.39	17.32	15.75	19.69
410	410	490	490	16.14	16.14	19.29	19.29
305	610	381	686	12	24	15	27
300	620	380	700	11.81	24.41	14.96	27.56
320	640	380	700	12.60	25.20	14.96	27.56
490	490	570	570	19.29	19.29	22.44	22.44
375	655	455	735	14.76	25.79	17.91	28.94
470	610	550	690	18.50	24.02	21.65	27.17
490	590	570	670	19.29	23.23	22.44	26.38
525	668	645	788	20.67	26.30	25.39	31.02
610	610	686	686	24	24	27	27
457	890	534	965	18	35	21	38
620	670	680	730	24.41	26.38	26.77	28.74
645	645	735	735	25.39	25.39	28.94	28.94
653	653	733	733	25.71	25.71	28.86	28.86
630	730	710	810	24.80	28.74	27.95	31.89
520	1020	600	1100	20.47	40.16	23.62	43.31
586	920	666	1000	23.07	36.22	26.22	39.37
500	1100	580	1180	19.69	43.31	22.83	46.46
610	915	686	991	24	36	27	39
750	750	830	830	29.53	29.53	32.68	32.68
750	840	830	920	29.53	33.07	32.68	36.22
801	801	880	880	31.54	31.54	34.65	34.65
610	1118	690	1198	24.02	44.02	27.17	47.17
610	1219	686	1295	24	48	27	51
645	1130	725	1210	25.39	44.49	28.54	47.64
720	1020	800	1100	28.35	40.16	31.50	43.31
915	915	991	991	36	36	39	39
920	920	1000	1000	36.22	36.22	39.37	39.37
915	1118	991	1194	36	44	39	47
1020	1020	1100	1100	40.16	40.16	43.31	43.31
1118	1118	1194	1194	44	44	47	47
1130	1130	1220	1220	44.49	44.49	48	48

\*\*Chart details standard size vents. Contact IEP for any custom requirements\*\*

# Explosion Vent KE

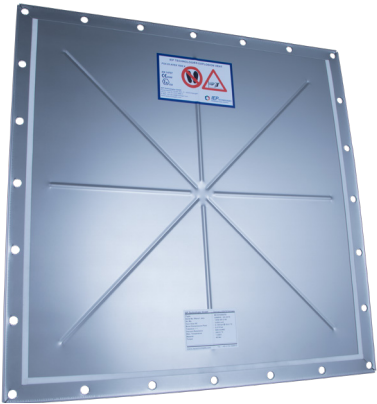

If the negative pressure is not greater than 60% of the rated rupture pressure, installation of a domed vent has no extra benefit. For this application the KE is an alternative to the domed GE. The KE provides long durability and aerodynamic advantages compared to the domed type, for example in cyclones. Pressure spike dampening, integrated flange gaskets, cross rib and folded edges are standard KE design features.

Millimeters				Inches			
Inside		Outside		Inside		Outside	
Length	Width	Length	Width	Length	Width	Length	Width
110	290	170	350	4.33	11.42	6.69	13.78
229	229	309	309	9.02	9.02	12.17	12.17
205	290	285	370	8.07	11.42	11.22	14.57
229	305	309	385	9.02	12.01	12.17	15.16
150	600	230	680	5.91	23.62	9.06	26.77
220	420	300	500	8.66	16.54	11.81	19.69
340	385	400	445	13.39	15.16	15.75	17.52
305	457	381	534	12	18	15	21
247	610	327	690	9.72	24.02	12.87	27.17
340	440	400	500	13.39	17.32	15.75	19.69
410	410	490	490	16.14	16.14	19.29	19.29
300	620	380	700	11.81	24.41	14.96	27.56
305	610	381	686	12	24	15	27
320	640	380	700	12.60	25.20	14.96	27.56
319	765	399	845	12.56	30.12	15.71	33.27
490	490	570	570	19.29	19.29	22.44	22.44
375	655	455	735	14.76	25.79	17.91	28.94
390	620	470	700	15.35	24.41	18.50	27.56
360	710	440	790	14.17	27.95	17.32	31.10
445	597	525	677	17.52	23.50	20.67	26.65
470	610	550	690	18.50	24.02	21.65	27.17
490	590	570	670	19.29	23.23	22.44	26.38
420	770	500	850	16.54	30.31	19.69	33.46
247	1345	327	1425	9.72	52.95	12.87	56.10
525	668	645	788	20.67	26.30	25.39	31.02

\*\*Chart details standard size vents. Contact IEP for any custom requirements\*\*

Millimeters				Inches			
Inside		Outside		Inside		Outside	
Length	Width	Length	Width	Length	Width	Length	Width
610	610	686	686	24	24	27	27
457	890	534	965	18	35	21	38
247	1645	327	1725	9.72	64.76	12.87	67.91
620	670	680	730	24.41	26.38	26.77	28.74
645	645	735	735	25.39	25.39	28.94	28.94
653	653	733	733	25.71	25.71	28.86	28.86
669	669	735	735	26.34	26.34	28.94	28.94
630	730	710	810	24.80	28.74	27.95	31.89
520	1020	600	1100	20.47	40.16	23.62	43.31
586	920	666	1000	23.07	36.22	26.22	39.37
610	915	686	991	24	36	27	39
500	1100	580	1180	19.69	43.31	22.83	46.46
750	750	830	830	29.53	29.53	32.68	32.68
420	1420	500	1500	16.54	55.91	19.69	59.06
629	1004	689	1064	24.76	39.53	27.13	41.89
750	840	830	920	29.53	33.07	32.68	36.22
801	801	880	880	31.54	31.54	34.65	34.65
500	1350	580	1430	19.69	53.15	22.83	56.30
610	1118	690	1198	24.02	44.02	27.17	47.17
610	1219	686	1295	24	48	27	51
645	1130	725	1210	25.39	44.49	28.54	47.64
720	1020	800	1100	28.35	40.16	31.50	43.31
915	915	991	991	36	36	39	39
920	920	1000	1000	36.22	36.22	39.37	39.37
970	970	1050	1050	38.19	38.19	41.34	41.34
915	1118	991	1194	36	44	39	47
1000	1000	1080	1080	39.37	39.37	42.52	42.52
586	1727	666	1807	23.07	67.99	26.22	71.14
1020	1020	1100	1100	40.16	40.16	43.31	43.31
790	1340	870	1420	31.10	52.76	34.25	55.91
720	1670	800	1750	28.35	65.75	31.50	68.90
1118	1118	1194	1194	44	44	47	47
1130	1130	1220	1220	44.49	44.49	48.03	48.03
1131	1131	1220	1220	44.53	44.53	48.03	48.03
920	1380	1000	1460	36.22	54.33	39.37	57.48
1130	1520	1220	1610	44.49	59.84	48.03	63.39
1118	1753	1193	1828	44	69	47	72
1130	1727	1230	1827	44.49	67.99	48.43	71.93
1000	2000	1080	2080	39.37	78.74	42.52	81.89

\*\*Chart details standard size vents. Contact IEP for any custom requirements\*\*

# Explosion Vent KER

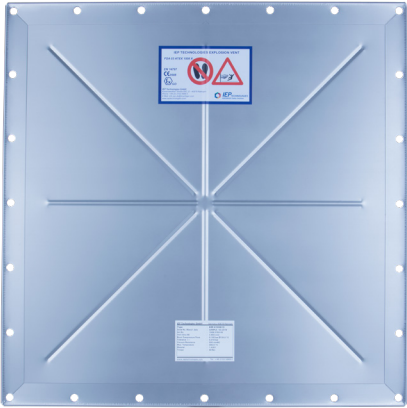

The KER style vent is perfect for standard applications in powder handling and storage. The KER is suitable for plant equipment with static over/under pressure conditions up to 50% of the rated rupture pressure. A unique feature with the KER is that edge reinforcement in its design allows the KER to be mounted without an outlet flange thus reducing installation costs. Cross rib and folded edges are standard KER design features. Each vent comes with an integrated flange gasket.

Millimeters				Inches			
Inside		Outside		Inside		Outside	
Length	Width	Length	Width	Length	Width	Length	Width
110	290	170	350	4.33	11.42	6.69	13.78
229	229	309	309	9.02	9.02	12.17	12.17
205	290	285	370	8.07	11.42	11.22	14.57
229	305	309	385	9.02	12.01	12.17	15.16
150	600	230	680	5.91	23.62	9.06	26.77
220	420	300	500	8.66	16.54	11.81	19.69
315	410	365	460	12.40	16.14	14.37	18.11
340	385	400	445	13.39	15.16	15.75	17.52
305	457	381	534	12	18	15	21
247	610	327	690	9.72	24.02	12.87	27.17
340	440	400	500	13.39	17.32	15.75	19.69
400	400	500	500	15.75	15.75	19.69	19.69
410	410	490	490	16.14	16.14	19.29	19.29
305	610	381	686	12	24	15	27
300	600	350	650	11.81	23.62	13.78	25.59
300	620	380	700	11.81	24.41	14.96	27.56
320	640	380	700	12.60	25.20	14.96	27.56
319	765	399	845	12.56	30.12	15.71	33.27
490	490	570	570	19.29	19.29	22.44	22.44
375	655	455	735	14.76	25.79	17.91	28.94
390	620	470	700	15.35	24.41	18.50	27.56
445	597	525	677	17.52	23.50	20.67	26.65
470	610	550	690	18.50	24.02	21.65	27.17
490	590	570	670	19.29	23.23	22.44	26.38

**\*\*Chart details standard size vents. Contact IEP for any custom requirements\*\***



Millimeters				Inches					
Length	Inside		Length	Outside	Length	Inside		Length	Outside
	Width	Width				Width	Width		
420	770		500	850	16.54	30.31	19.69	33.46	
247	1345		327	1425	9.72	52.95	12.87	56.10	
525	668		645	788	20.67	26.30	25.39	31.02	
610	610		686	686	24	24	27	27	
600	600		650	650	23.62	23.62	25.59	25.59	
247	1645		327	1725	9.72	64.76	12.87	67.91	
457	890		534	965	18	35	21	38	
620	670		680	730	24.41	26.38	26.77	28.74	
645	645		735	735	25.39	25.39	28.94	28.94	
653	653		733	733	25.71	25.71	28.86	28.86	
669	669		735	735	26.34	26.34	28.94	28.94	
630	730		710	810	24.80	28.74	27.95	31.89	
620	820		675	875	24.41	32.28	26.57	34.45	
520	1020		600	1100	20.47	40.16	23.62	43.31	
586	920		666	1000	23.07	36.22	26.22	39.37	
500	1100		580	1180	19.69	43.31	22.83	46.46	
610	915		686	991	24	36	27	39	
750	750		830	830	29.53	29.53	32.68	32.68	
420	1420		500	1500	16.54	55.91	19.69	59.06	
629	1004		689	1064	24.76	39.53	27.13	41.89	
750	840		830	920	29.53	33.07	32.68	36.22	
800	800		850	850	31.50	31.50	33.46	33.46	
801	801		880	880	31.54	31.54	34.65	34.65	
500	1350		580	1430	19.69	53.15	22.83	56.30	
610	1118		690	1198	24.02	44.02	27.17	47.17	
610	1219		686	1295	24	48	27	51	
645	1130		725	1210	25.39	44.49	28.54	47.64	
720	1020		800	1100	28.35	40.16	31.50	43.31	
915	915		991	991	36	36	39	39	
920	920		1000	1000	36.22	36.22	39.37	39.37	
940	940		1000	1000	37.01	37.01	39.37	39.37	
970	970		1050	1050	38.19	38.19	41.34	41.34	
915	1118		991	1194	36	44	39	47	
1000	1000		1050	1050	39.37	39.37	41.34	41.34	
1000	1000		1080	1080	39.37	39.37	42.52	42.52	
586	1727		666	1807	23.07	67.99	26.22	71.14	
1020	1020		1100	1100	40.16	40.16	43.31	43.31	
790	1340		870	1420	31.10	52.76	34.25	55.91	
720	1670		800	1750	28.35	65.75	31.50	68.90	
1118	1118		1194	1194	44	44	47	47	
1130	1130		1220	1220	44.49	44.49	48.03	48.03	
1131	1131		1220	1220	44.53	44.53	48.03	48.03	
920	1380		1000	1460	36.22	54.33	39.37	57.48	
940	1440		1000	1500	37.01	56.69	39.37	59.06	
1130	1520		1220	1610	44.49	59.84	48.03	63.39	
1118	1753		1193	1828	44	69	47	72	
1130	1727		1230	1827	44.49	67.99	48.43	71.93	
1000	2000		1080	2080	39.37	78.74	42.52	81.89	

**\*\*Chart details standard size vents. Contact IEP for any custom requirements\*\***

# Explosion Vent GT



The round GT type vent is specifically designed for applications with increased Pstat levels. Special applications with elevated operating pressure require explosion vents with static opening pressures that exceed the standard of 0,1barg.

The GT type vent series is available from DN 200mm up to DN1100mm and can be adjusted with Pstat levels of up to 0,5bar even at elevated process temperatures.

Size DN	Millimeters		Inches	
	Inside Dimensions	Outside Dimensions	Inside Dimensions	Outside Dimensions
200	208	268	8,2	10,6
250	261	341	10,3	13,4
300	310	390	12,2	15,4
350	342	422	13,5	16,6
400	393	473	15,5	18,6
450	465	545	18,3	21,5
500	494	574	19,4	22,6
600	596	676	23,5	26,6
700	696	776	27,4	30,6
750	762	842	30	33,1
800	797	877	31,4	34,5
900	894	974	35,2	38,3
1000	995	1075	39,2	42,3

**\*\*Chart details standard size vents. Contact IEP for any custom requirements\*\***

## Gaskets

All vents are supplied with “factory-installed” integrated flange gaskets. The standard material is EPDM and can be used from -40 °C to +120 °C. As an alternative the following standard materials are available:

White FDA Silicone - 50 °C to +200 °C

Klinger - 100 °C to +400 °C

Ceramic -100°C to +900 °C

Other materials can be supplied on request



# Accessories

## Mounting Frames

The necessary outlet flange for types GE / KE can also be supplied. The following material is available: Zinc plated carbon steel or stainless steel.

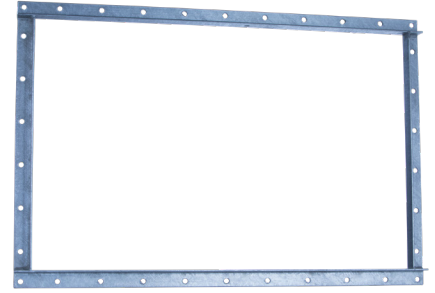

## Insulation

Insulation consists of a fire-proof mineral wool according to DIN 1259. The insulation is directly mounted to the “vent-side” of the explosion vent and is protected by a light-weight aluminium cover with a water-tight seal. It is secured to the disc to prevent it from flying away during venting. IEP insulation does not have any effect on the venting relief capability or efficiency. This has been proved by notified bodies in many dynamic explosion tests. Insulation is available in different thicknesses to match your process demands and meet the customer’s specifications.



## Burst Sensor - SE

To monitor an installation a burst sensor type SE can be installed. The sensor signals the opening of the IEP Technologies explosion vent so that equipment such as fans or rotary valves can be switched off. SE sensors can be retrofitted to every explosion vent on existing installations. The sensors are suitable for applications in the food industry.



## Burst Sensor - SE - HT

The SE sensor is complemented by the HT sensor, which is also suitable for use at high temperatures.



## Burst Sensor SE - WIRE

Another alternative is the Sensor SE - WIRE.

The cable loop is torn when the explosion vent is opened. It results in the electric circuit interruption and a continuous, high resistance signal is generated. The signal indicates the opening of the explosion vent and can be used in the control system.



# Flameless Explosion Venting

In cases where standard explosion venting cannot be used due to the plant part being located indoors or where no means of venting into a safe place can be realised, flameless venting offers a great alternative.

The unique IEP Technologies flameless vents are designed to escaping flame front and relieve the pressure to the surrounding in a safe way, without the need for an expendable rupture panel.

A flameless venting system always consists of two parts: One is the venting device which is completed with a downstream flame arrester. Whereas the venting device mainly protects the dangerous rise of explosion pressure in the process equipment the flame

arrester is used to dissipate the energy of the expelled combustion flames into its material. By reducing the gas temperature to a safe level, flameless venting can be used in areas where it would be impossible to safely use an explosion vent only.

The IEP Technologies Explosion relief valves are unique in its design. A valve plate closes the vent orifice backed up by a conical valve spring, thus maintaining the opening pressure. The flame arrester is integral to the valve design case of an explosion, the valve plate opens in fractions of a second, releasing the overpressure in the protected process equipment. The hot gases are forced through the flame arrester in radial direction thus cooling down the flames. Once the deflagration pressure dissipates inside the protected vessel, the valve spring re-sets the valve plate.

Flameless venting offers a great solution for many applications and as with other explosion protection methods, has its own superior suitability for certain configurations. In cases where it can not be used, the IEP Technologies Suppression systems can be offered as an alternative protection option.

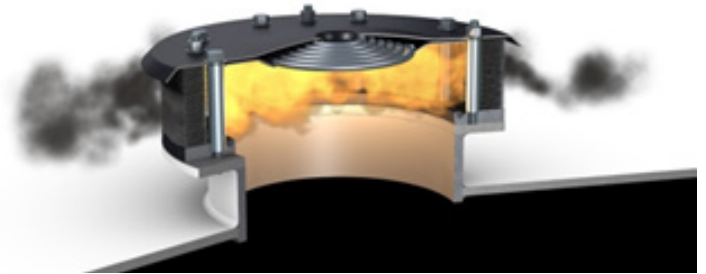
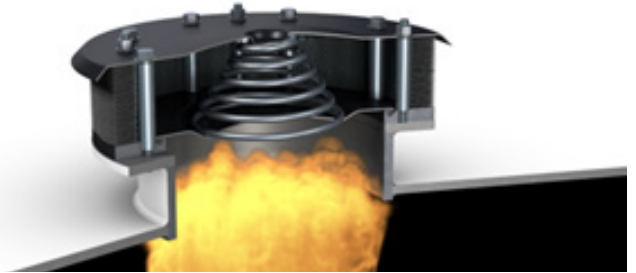

# EVN 2.0

The reliable and proven design of the EVN 2.0 Flameless Explosion relief valve offers low profile mounting, low opening pressure and full vacuum resistance. The standard range features an opening pressure of 0,05 bar +/- 20%. Standard range components are made of carbon steel, coated. Special materials are available on request. Each valve is equipped with an opening detection as standard. For specific efficiency values (%EF) mandatory for correct sizing of the necessary relief area, please contact the manufacturer.

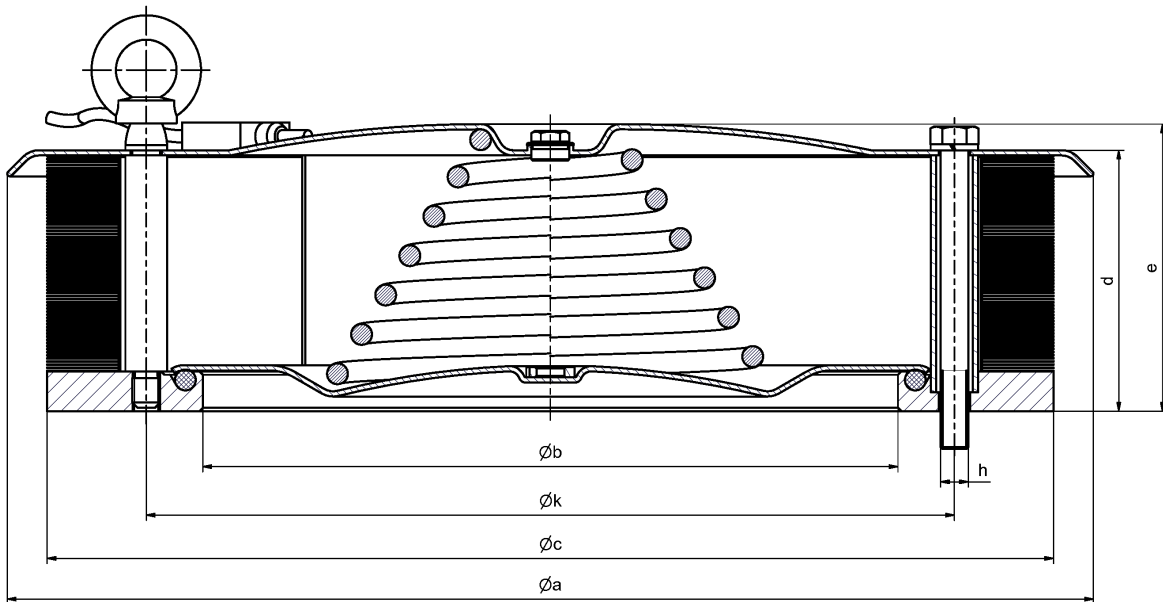

Type	Geom. Relief Area (cm <sup>2</sup> )	Dimensions					Connection			Approx. Weight [kg]
		a.	b.	c.	d.	e.	No. of bolts	h	k	
		[mm]	[mm]	[mm]	[mm]	[mm]		Thread	P.C.D [mm]	
266EVN 2.0	499	457	252	409	114	134	6	M12 or 1/2"	302	29
320EVN 2.0	732	510	30	462	121	142	6	M12 or 1/2"	355	37
420EVN 2.0	1260	625	400	579	150	165	8	M16 or 5/8"	465	65
480EVN 2.0	1665	690	460	644	168	201	8	M16 or 5/8"	530	80
565EVN 2.0	2300	790	541	735	197	228	12	M16 or 5/8"	615	115
645EVN 2.0	2990	955	617	899	202	233	12	M16 or 5/8"	700	160
735EVN 2.0	3905	970	705	910	222	260	12	M16 or 5/8"	795	200



# EVN 3.0



**The newest addition to the portfolio is the EVN 3.0H Flameless vent.**

Specifically designed for processes with higher demands to process hygiene and in place cleaning capabilities. The EVN 3.0H features a unique food grade silicone quality lip seal featuring a flush inside geometry and acts as a flange gasket in one unit. The stainless steel valve plate in conjunction with an appropriate shape of the process outlet flange makes it perfectly suitable for processes which demand a low crevice design.

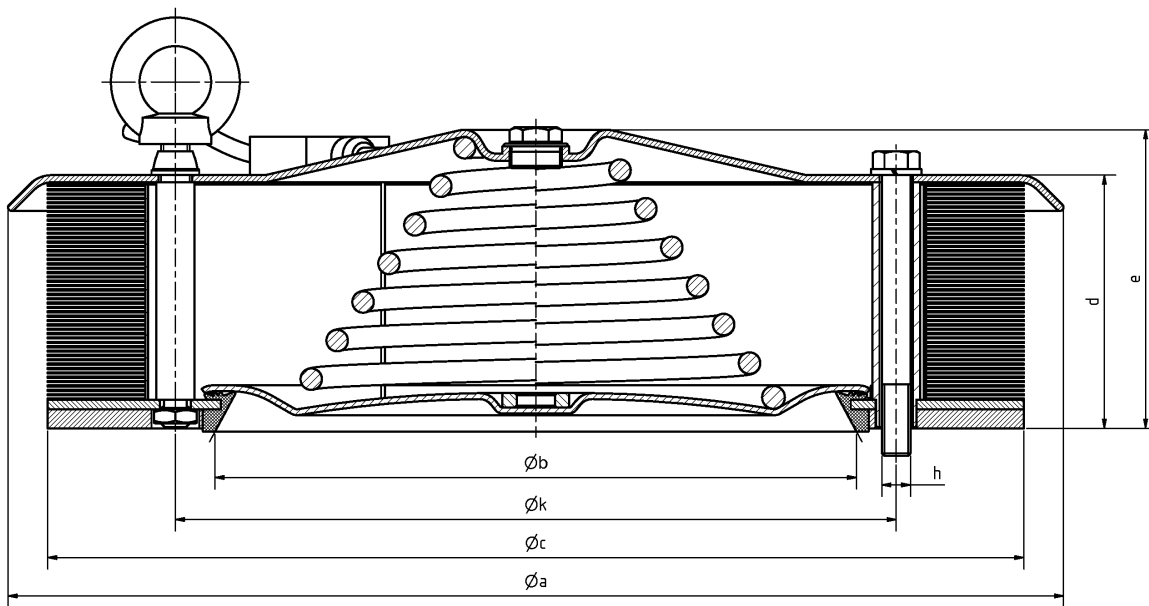

Type	Geom. Relief Area (cm <sup>2</sup> )	Dimensions					Connection			Approx. Weight [kg]
		a. [mm]	b. [mm]	c. [mm]	d. [mm]	e. [mm]	No. of bolts	h Thread	k P.C.D [mm]	
266EVN 3.0	499	442.2	268.6	409	106	126	6	M12 or 1/2"	302	24
320EVN 3.0	732	510	321.5	462	112	132	6	M12 or 1/2"	355	29.1
420EVN 3.0	1260	625	416.6	579	141.5	156.5	8	M16 or 5/8"	465	48
480EVN 3.0	1665	690	476.6	644	159.5	192.5	8	M16 or 5/8"	530	57
565EVN 3.0	2300	790	562.2	735	188	213	12	M16 or 5/8"	615	90
645EVN 3.0	2990	961	637.7	899	193	218	12	M16 or 5/8"	700	109
735EVN 3.0	3920	961	727.7	910	213	251	12	M16 or 5/8"	795	140



## EV 3.0 Explosion vent

For applications where only the great reclosing functionality of the Relief valve is needed, the EV3.0 is a perfect solution. Reusable, superior resistance against vibration and full vacuum resistance are the main features of this valve series. It uses the same lip seal geometry as known from the hygienic EVN 3.0H version.

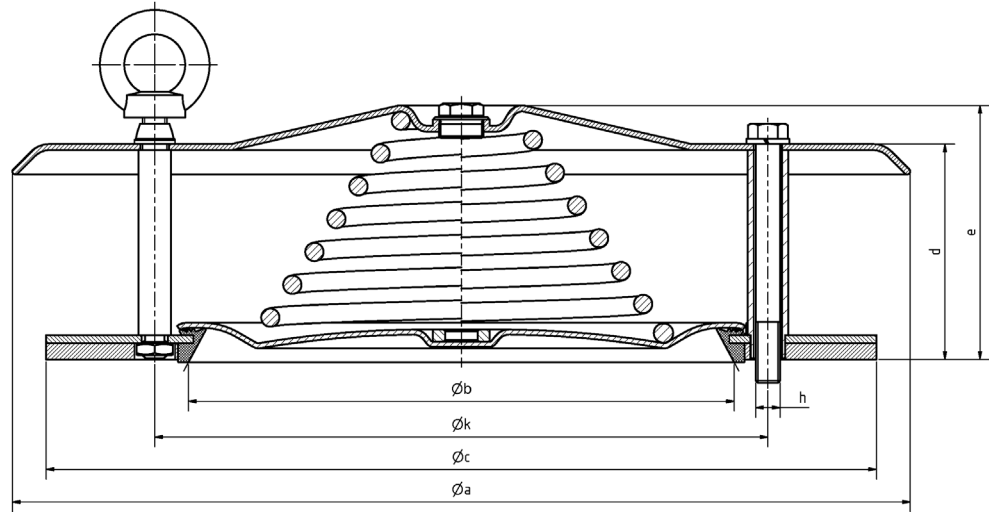

Type	Geom. Relief Area (cm <sup>2</sup> )	Dimensions					Connection			Approx. Weight [kg]
		a. [mm]	b. [mm]	c. [mm]	d. [mm]	e. [mm]	No. of bolts	h Thread	k P.C.D [mm]	
266EV 3.0	499	442.2	268.6	409	106	126	6	M12 or 1/2"	302	14
320EV 3.0	732	510	321.5	462	112	132	6	M12 or 1/2"	355	18.4
420EV 3.0	1260	625	416.6	579	141.5	156.5	8	M16 or 5/8"	465	32.5
480EV 3.0	1665	690	476.6	644	159.5	192.5	8	M16 or 5/8"	530	40.6
565EV 3.0	2300	790	562.2	735	188	213	12	M16 or 5/8"	615	64.7
645EV 3.0	2990	961	637.7	899	193	218	12	M16 or 5/8"	700	87
735EV 3.0	3920	961	727.7	910	213	251	12	M16 or 5/8"	795	91



## Non reclosing Explosion relief valves NC option

For special applications the reclosing feature of the Explosion relief valves is not preferred. For these applications, a non-reclosing flameless vent can be provided. These devices are designed to be manually reset after a deflagration. Ask your sales representative for detailed information on this product line.



## The Next Step

You can't afford to let an explosion threaten your facility. Let us work with you to keep industrial explosions from impacting your bottom line. Call IEP Technologies today.

### Europe

**IEP Technologies - Austria**  
(HOERBIGER Safety Solutions)  
Tel. +43 (1) 740040

**IEP Technologies - Belgium**  
(HOERBIGER Safety Solutions)  
Tel. +32 (478) 292669

**IEP Technologies - Finland**  
Tel. +358 (10) 3253580

**IEP Technologies - UK**  
Tel: +44 (0) 1242 283 060

**IEP Technologies - France**  
Tel: +33 (0) 1 5803 3980

**IEP Technologies - Germany**  
Tel: +49 (0) 2102 5889 0

**IEP Technologies - Italy**  
(HOERBIGER Safety Solutions)  
Tel. +39 (045)2370762

**IEP Technologies - Sweden**  
(HOERBIGER Safety Solutions)  
Tel. +46 (70) 5643306

**IEP Technologies - Switzerland**  
Tel: +41 (0) 62 207 10 10

**IEP Technologies - Turkey**  
Tel: +90 232 484 4412

### North & South America

**IEP Technologies - USA**  
Tel: +1-855-793-8407

**IEP Technologies - Latin America**  
(HOERBIGER Safety Solutions)  
Tel: +55 (11) 4446 7400

### Asia

**IEP Technologies - China**  
(HOERBIGER Safety Solutions)  
Tel: +86 21 6485 0855 Ext 8211

**IEP Technologies - South East Asia**  
(HOERBIGER Safety Solutions)  
Tel: +65 8127 0321