

FUNCTION

- The VIGIBELT® TOUCH is a lateral movement sensor that detects run-out of elevator belts or conveyor belts, and at the same time the run-out of the lift pulley. It reacts to the pressure of the belt coming into contact with the front face of the sensor. Baffle plates are usually fitted opposite each other, preferably on the upward leg close to the pulleys for elevators, and on the load bearing side close to the drums for conveyors.

The sensors can be connected directly to a PLC, or for absolutely safety, to an independent "monitoring M-JET" central unit. The electrical circuit can control an alarm or a machine shut down.

- For elevators more than 20 meters long, we recommend fitting the head with a second VIGIBELT® TOUCH kit, still on the upward leg.
- The sensors trigger when the belt applies a force of approximately 5 daN.

DESCRIPTION

- The VIGIBELT® TOUCH kit comprises two sensors, four elastomer spacers (3mm NBR) and the fastenings (M6).







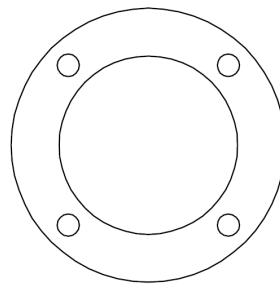
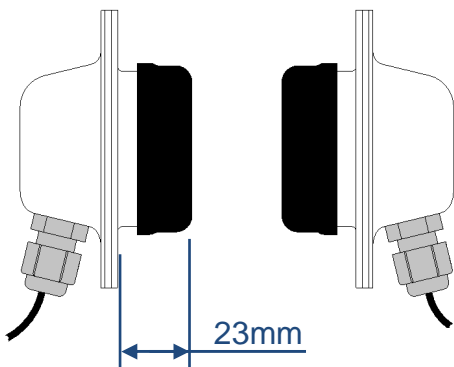

Composition :

2x VIGIBELT® TOUCH

4x elastomer spacers (th.3mm)

8x mounting bolts (M6)



		8x
		8x
		8x
		8x

PRECAUTIONS

The VIGIBELT® TOUCH must be installed, connected and put into service by competent personnel. The personnel should be qualified electricians and know the regulations and requirements concerning the installation of these appliances, especially when installed in ATEX areas.

- Carry out a study prior to the electrical connection of the VIGIBELT® TOUCH sensors (standardised electrical diagram, PLC control, electricity supply and protection).
- Define the sensing distance between the belt and the elevator shaft (confirmation of the triggering distance by the person in charge of the site).
- Before any installation or intervention on the VIGIBELT® TOUCH, it is essential to make sure that the bucket elevator is shut down (intervention warning to be posted on the machine).
- When the VIGIBELT® TOUCH is dismantled, the user should ensure that the appliance is scrapped properly and that the components are passed to the appropriate specialist collection centres according to their nature (stainless steel, electrical equipment, seals, etc.).

INSTALLATION

- 1) Make two symmetrical round openings on each side of the up shaft of an elevator (56mm dia. + 4 7mm dia. holes on a PCD of 72mm): **Diagram-A**

Diagram A

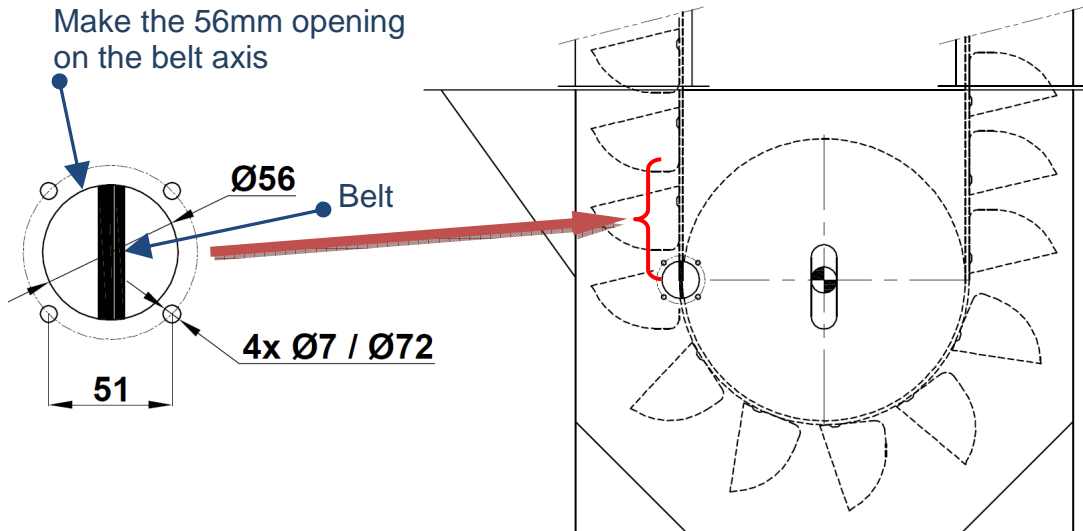

On a bucket elevator position the VIGIBELT® TOUCH sensors on the upward leg close to the axis of the pulleys and the belt.

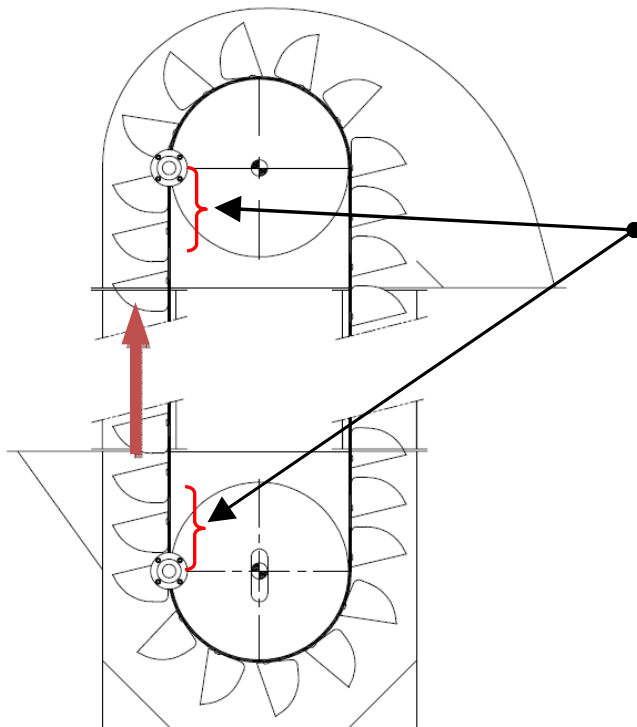

On a conveyor belt position the VIGIBELT® TOUCH sensors on the load carrying side close to the axis of the drum and the belt.

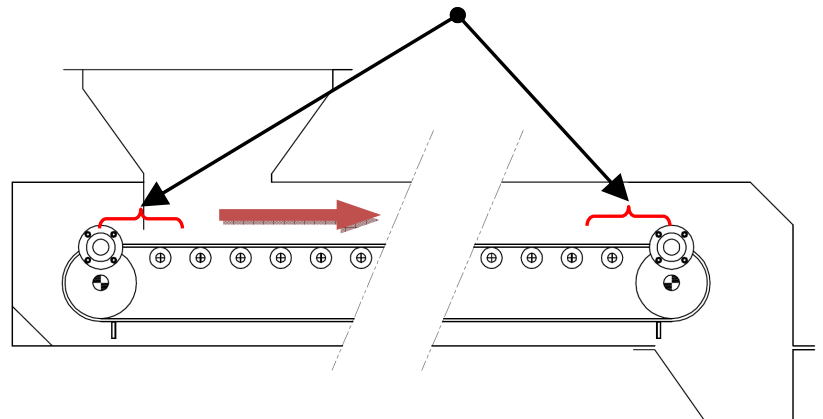
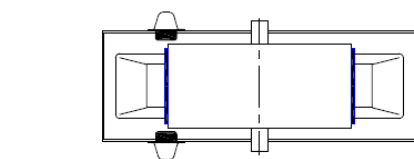

2) Fit the M6 pan head screws with the low nuts on the shaft (torque 6 N.m): **Diagram-B.**

Diagram B

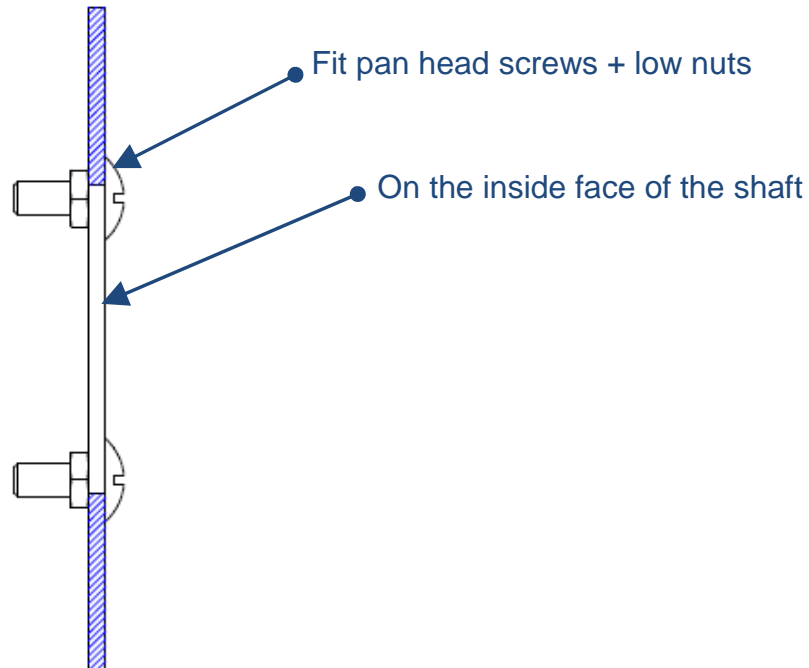

3) Adjust the triggering distance of the VIGIBELT® TOUCH sensors. This distance is the dimension between the inside face of the elevator and the contact face of the sensor.

To achieve this, three detection adjustments are possible, **diagram-C:**

- No 1 - Sensor with no additional spacer, elevator thickness (e.g.: 3mm), i.e. a distance of **20mm**
- No 2 - Sensor with one additional spacer, elevator thickness (e.g.: 3mm), i.e. a distance of **17mm**
- No 3 - Sensor with two additional spacers, elevator thickness (e.g.: 3mm), i.e. a distance of **14mm**

Diagram C

Adjustment no 1
Distance of 20mm,
With no additional spacer

Adjustment no 2
Distance of 17mm,
with one additional spacer

Adjustment no 3
Distance of 14mm,
with two additional spacers

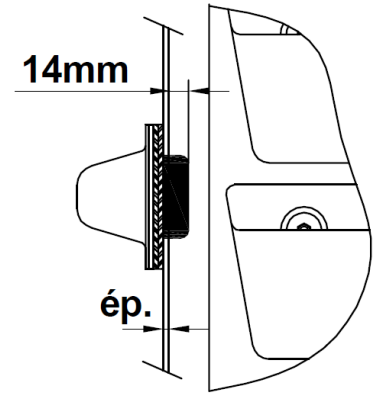
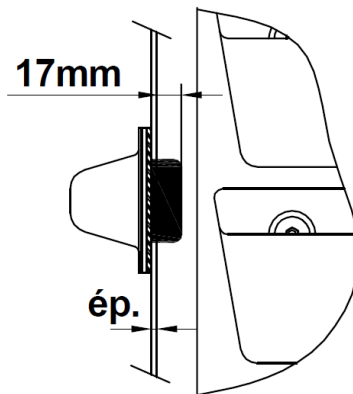
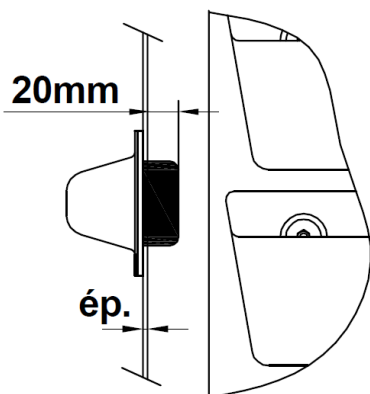

- 4) Position the VIGIBELT® TOUCH sensors on the openings and tighten the M6 locknuts (torque 4 N.m) according to **Diagram-D**.

Diagram D

Fix the VIGIBELT® TOUCH sensor with the washers and locknuts

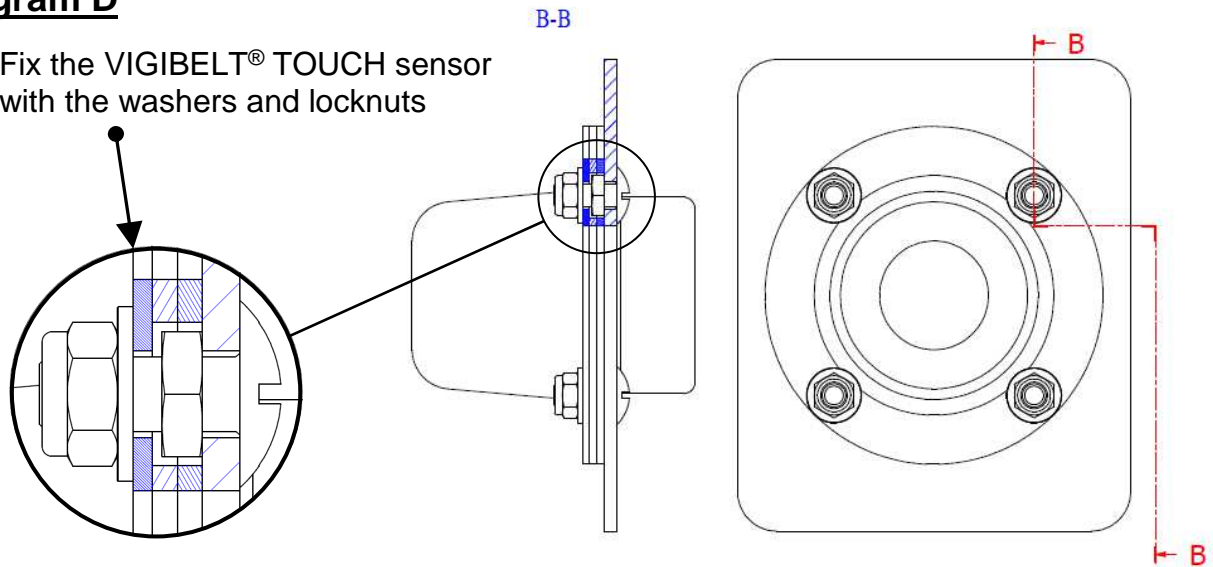

- 5) Connect the VIGIBELT® TOUCH sensors according to the electrical diagrams:

NC sensor = positive safety, continuous sensor function monitoring

Loss of the signal indicates a problem of

- ⇒ Belt run-out
- ⇒ Wiring open circuit

VIGIBELT® TOUCH - 55KVT95042ME

- Connection by cable : PVC 2m (3 wires)
- Rated supply voltage :12...250V AC/DC
- Protection – IP 67 according to IEC 60529
- NC : wire Black (1) / wire Grey (2)
- NO : wire Black (1) / wire Blue (4)
- Temp : -20...+105° C

Connection diagram - 3 wires

Wire colours

1 = Black

2 = Grey

4 = Blue

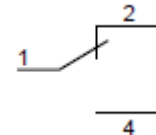

Cable :3x0.25mm²

- 6) After completing the mechanical and electrical installation of the VIGIBELT® TOUCH sensors, you should check each sensor to make sure that they are all working. To do this, trigger each sensor by pressing its contact face. This simulation serves to confirm that the fault information is transmitted to the monitoring system (monitoring M-JET, supervisor PLC).