

Certified Rotary Valve EMVDL-RVEX-MD

APPLICATIONS

- Passive explosion isolation requiring rotor access for frequent cleaning
- Differential pressures **up to 400" WG**
- Heavy Duty design, ideal for high vacuum applications
- Recommended for pneumatic conveying of process material and dust feeder valve for screw conveyors, scales, classifiers dryers and coolers

CERTIFICATIONS & STANDARDS

EN 15089

CE 0588 ⚡ II ID/* c T4 ⚡ D FSA 15 ATEX 1661/1662 X

NFPA 69 compliant

Flex tip design certified to prevent flame passage

NFPA 69 12.2.4.3.6 compliant

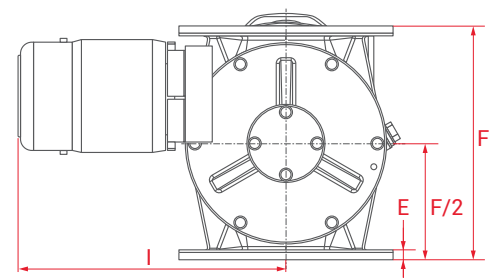
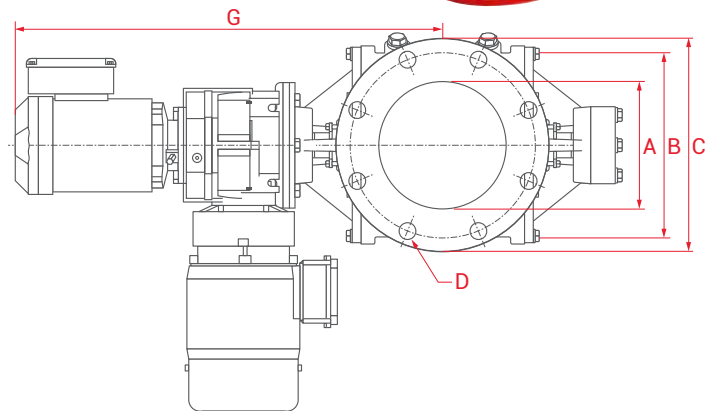
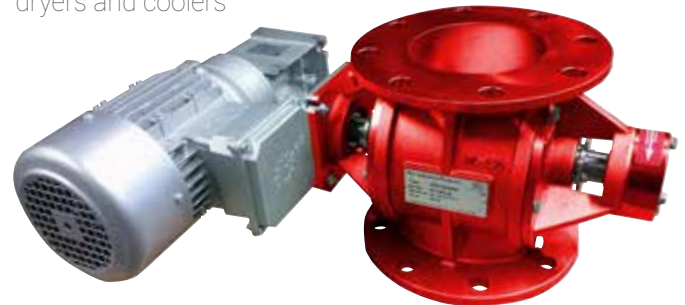

STANDARD FEATURES

- Explosion & Flame Proof design to **36 psi / 2.5 bar** (**25 psi / 1.7 bar** with polyurethane flex tip rotor)
- Cast iron housing with round inlet and outlet
- Direct Drive **15 RPM, IP65 gearmotor** w/flex coupling
- Removable 8 vane polyurethane, steel or S/S rotor
- Adjustable Gland Pack bearings for shaft sealing
- High fill ratio with very low leakage & product damage

OPTIONAL FEATURES

- Motors for hazardous locations and extreme temperature
- **30 RPM** gearmotor with EM variable speed control package
- Special construction, stainless steel, chromium/nickel plating
- Insulation box, speed monitors, flange gasket, injector fittings and product scrapers

DIMENSIONS *

| MODEL | 15 RPM HP | 30 RPM HP | CAPACITY FT ³ (LTR) | Ø A | Ø B | Ø C | D | E | F | G | H | I |
|------------------|-----------|-----------|--------------------------------|--------------|--------------|--------------|-------------|---------------|--------------|--------------|--------------|--------------|
| EMVDL RVEX-MD150 | 0.50 | 0.75 | 0.10 (3)/rev | 6" (150 mm) | 9" (240 mm) | 11" (285 mm) | 8 x Ø23 mm | 0.51" (13 mm) | 10" (260 mm) | | 13" (330 mm) | 14" (355 mm) |
| EMVDL RVEX-MD200 | 0.75 | 1.50 | 0.39 (11)/rev | 8" (200 mm) | 12" (300 mm) | 13" (340 mm) | 8 x Ø23 mm | 0.51" (13 mm) | 15" (370 mm) | | 16" (400 mm) | 21" (525 mm) |
| EMVDL RVEX-MD250 | 1.00 | 1.00 | 0.74 (21)/rev | 10" (250 mm) | 14" (350 mm) | 16" (395 mm) | 12 x Ø23 mm | 0.67" (17 mm) | 17" (425 mm) | 30" (770 mm) | | |
| EMVDL RVEX-MD300 | 1.50 | 3.00 | 1.30 (37)/rev | 12" (300 mm) | 16" (400 mm) | 18" (445 mm) | 12 x Ø23 mm | 0.79" (20 mm) | 20" (500 mm) | 33" (840 mm) | | |

Columns G, H and I depend on drive

* Units in inches rounded to the closest whole number