

Certified Rotary Valve EMVDL-RVEX-HT

APPLICATIONS

- Passive explosive isolation. ATEX EN 15089 / NFPA 69
- Differential pressures up to 40" WG
- Rotary airlock for dust collectors and cyclones
- Feeder valve for screw conveyors, scales, dryers and coolers

CERTIFICATIONS & STANDARDS

EN 15089

CE 0588 II ID/* c T4 D FSA 15 ATEX 1661/1662 X

NFPA 69 compliant

Flex tip design certified to prevent flame passage

NFPA 69 12.2.4.3.6 compliant



STANDARD FEATURES

- Explosion & Flame Proof design rated up to **25 psi / 1.7 bar**
- Cast iron body with flanged round inlet/outlet
- **NFPA 69** Compliant with **8 blade rotor**, polyurethane flex-tips
- External oil / bronze bearings with felt shaft seal
- **15 RPM** direct drive gearmotor with flex coupling, **USA Mfg**

OPTIONAL FEATURES

- Motors for hazardous locations and extreme temperature
- **30 RPM** gearmotor with EM variable speed control package
- Special construction such as stainless steel, chromium or nickel plating, quick disassembly
- Insulation box, speed monitors, flange gasket, injector fittings and product scrapers

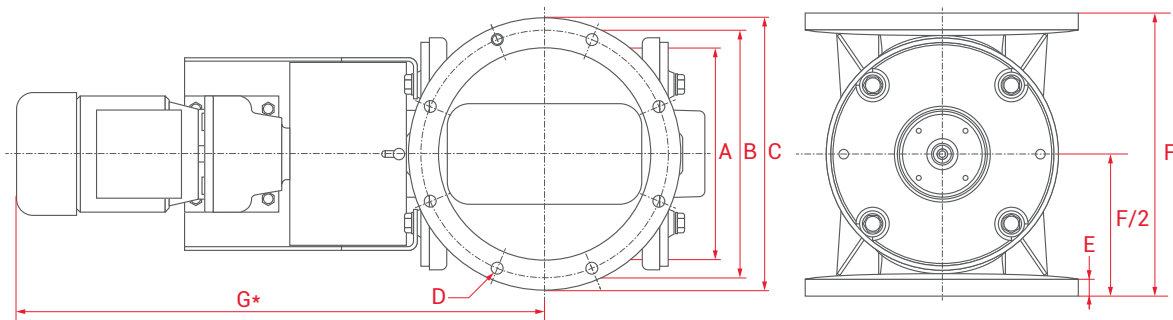

DIMENSIONS*

MODEL	15 RPM HP	30 RPM HP	CAPACITY FT ³ (LTR)	Ø A	Ø B	Ø C	D	E	F*	G
EMVDL RVEX-HT250	0.33	0.75	0.24 (7)/rev	10" (250 mm)	12" (290 mm)	13" (320 mm)	8 x Ø12 mm	0.79" (20 mm)	13" (330 mm)	24" (620 mm)
EMVDL RVEX-HT350	0.50	1.00	0.70 (20)/rev	14" (340 mm)	15" (390 mm)	17" (420 mm)	8 x Ø12 mm	0.79" (20 mm)	16" (400 mm)	26" (670 mm)
EMVDL RVEX-HT450	1.00	2.00	1.23 (35)/rev	17" (420 mm)	19" (490 mm)	21" (525 mm)	8 x Ø12 mm	0.79" (20 mm)	20" (500 mm)	33" (850 mm)

SQUARE TO ROUND TRANSITIONS*

SQUARE TRANSITION (Nominal Size Inches)	6X6	8X8	10X10	12X12	14X14	16X16
Model : EMVDL-RVEX	HT250	HT250	HT250	HT350	HT350	HT450
Transition Height	2.84" (72 mm)	2.80" (71 mm)	2.80" (71 mm)	2.80" (71 mm)	2.80" (71 mm)	3.43" (87 mm)
Overall Height (Dim F + Transition Height)	16" (402 mm)	16" (401 mm)	16" (401 mm)	19" (471 mm)	19" (471 mm)	23" (587 mm)

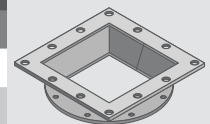

* Length varies dependent on motor selection – Units in inches rounded to the closest whole number