



MINI-MIST COLLECTOR

MODELS MM 500 AND MM 1200

Compact, machine-mountable mist collectors dedicated for use on combined machine operations.

- Three stage filtration for high filtration efficiency and optimum filter life
- Handles mist, smoke, and particulate applications up to 1200 cfm (2038 m³/h)
- Standard Minihelic[®] gauge indicates when filter maintenance is required
- Hinged access doors makes filter changeout easy and simple
- Provides a cleaner work environment for maximum productivity
- Helps support OSHA Clean Air Standards
- Optional HEPA filter is available on all models

Designed to filter contaminants from machining operations and industrial processes.

- CNC machining
- Grinding
- Turning
- Milling
- Drilling operations



MM 1200
with Optional HEPA



MM 1200
with Optional Junction Box

STANDARD FEATURES & AVAILABLE OPTIONS

| STANDARD | OPTIONAL |
|--------------------------------------|---|
| Three-stage filtration | Inlet hose kit |
| Direct-drive fans — ½, 1, and 1½ hp | High efficiency first-stage filter (MM 1200 only) |
| Hinged access door | P-Trap (MM 1200 only) |
| High-loft, fine-fiber primary filter | Inlet plenum (MM 1200 only) |
| 10-year warranty | Support legs (MM 1200 only) |

DIMENSIONS & SPECIFICATIONS

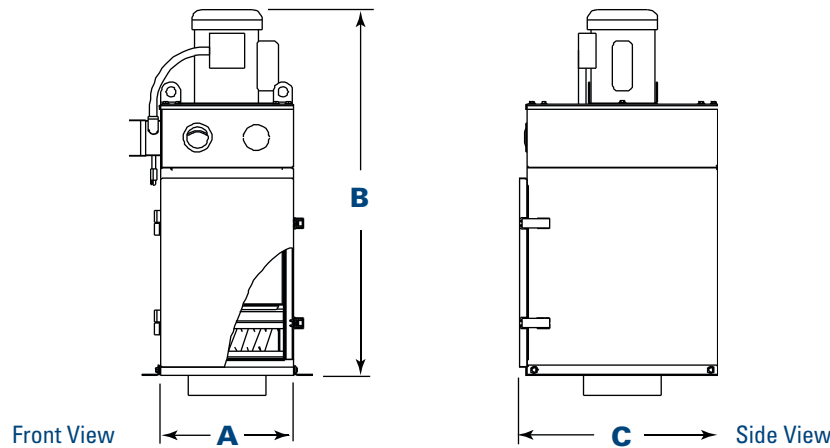

| Model | Description | Nominal Airflow* | | 1st Stage | 2nd Stage | 3rd Stage | Inlet Collars | Dimensions | | | | | | Shipping Weight | |
|--------------------------------|--|------------------|-------------------|---------------------------------|----------------------------|----------------------------------|--|------------|-------|------|--------|------|-------|-----------------|-------|
| | | | | | | | | A | | B | | C | | | |
| | | cfm | m ³ /h | | | | | in | mm | in | mm | in | mm | lb | kg |
| MM 500 | Machine-mountable, 3-stage filtration, ½ hp power pack | 500 | 849 | 4" (101.6 mm) aluminum impinger | 1" (25.4 mm) aluminum mesh | 95% high-loft glass fiber filter | 6" (152.4 mm), 8" (203.2 mm) | 13.5 | 342.9 | 39.2 | 995.7 | 20.3 | 515.6 | 95 | 43.1 |
| MM 500 with HEPA option | Machine-mountable, 3-stage filtration plus HEPA filter, ½ hp power pack | 300 | 510 | 4" (101.6 mm) aluminum impinger | 1" (25.4 mm) aluminum mesh | 95% high-loft glass fiber filter | 6" (152.4 mm), 8" (203.2 mm) | 13.5 | 342.9 | 49.7 | 1262.4 | 20.3 | 515.6 | 120 | 54.4 |
| MM 1200 1 hp | Machine-mountable, 3-stage filtration, 1 hp power pack | 1000 | 1699 | 4" (101.6 mm) aluminum impinger | 1" (25.4 mm) aluminum mesh | 95% high-loft glass fiber filter | 6" (152.4 mm), 8" (203.2 mm), 10" (254.0 mm) | 25.5 | 647.7 | 41.4 | 1051.6 | 24.3 | 617.2 | 285 | 129.3 |
| MM 1200 1 hp with HEPA option | Machine-mountable, 3-stage filtration plus HEPA filter, 1 hp power pack | 800 | 1359 | 4" (101.6 mm) aluminum impinger | 1" (25.4 mm) aluminum mesh | 95% high-loft glass fiber filter | 6" (152.4 mm), 8" (203.2 mm), 10" (254.0 mm) | 25.5 | 647.7 | 54.7 | 1389.4 | 24.3 | 617.2 | 350 | 158.8 |
| MM 1200 1½ hp | Machine-mountable, 3-stage filtration, 1½ hp power pack | 1200 | 2038 | 4" (101.6 mm) aluminum impinger | 1" (25.4 mm) aluminum mesh | 95% high-loft glass fiber filter | 6" (152.4 mm), 8" (203.2 mm), 10" (254.0 mm) | 25.5 | 647.7 | 41.4 | 1051.6 | 24.3 | 617.2 | 290 | 131.5 |
| MM 1200 1½ hp with HEPA option | Machine-mountable, 3-stage filtration plus HEPA filter, 1½ hp power pack | 950 | 1614 | 4" (101.6 mm) aluminum impinger | 1" (25.4 mm) aluminum mesh | 95% high-loft glass fiber filter | 6" (152.4 mm), 8" (203.2 mm), 10" (254.0 mm) | 25.5 | 647.7 | 54.7 | 1389.4 | 25.3 | 642.6 | 355 | 161.0 |

* Based on clean filters.

Important Notice

Many factors beyond the control of Donaldson can affect the use and performance of Donaldson products in a particular application, including the conditions under which the product is used. Since these factors are uniquely within the user's knowledge and control, it is essential the user evaluate the products to determine whether the product is fit for the particular purpose and suitable for the user's application. All products, product specifications, availability and data are subject to change without notice, and may vary by region or country.



CAPT-AIR®

8001 Rue Larrey, Anjou, QC, Canada, H1J 2L4
 514-273-4331 • info@capt-air.com • www.capt-air.com