



## DRYFLO® MIST COLLECTORS

MODELS DMC-MMA AND DMC-MMB

Dryflo® mist collectors from Donaldson® Torit® are effective and efficient mist filtration solutions, providing a more productive work environment by reducing coolant and machining oil mists in a machine-mountable package. The Dryflo® provides high performance technology and easy, predictable maintenance.

- High performance three-stage filtration improves collection efficiency at every stage
- Provides a cleaner work environment for maximum productivity
- Reduces risk of mist related hazards
- Quick and easy filter changes—workers have minimal contact with collected oil
- Predictable maintenance with a differential pressure gauge
- Lower plant maintenance costs
- Mounts directly onto a machining center to collect oil, water-soluble, semi-synthetic and synthetic coolant
- Low profile
- 10-year warranty
- Helps support OSHA Clean Air Standards



**Dryflo**  
Model DMC-MMA



Easy filter changeout

### NORMAL OPERATION FOR DMC-MMA, -MMB

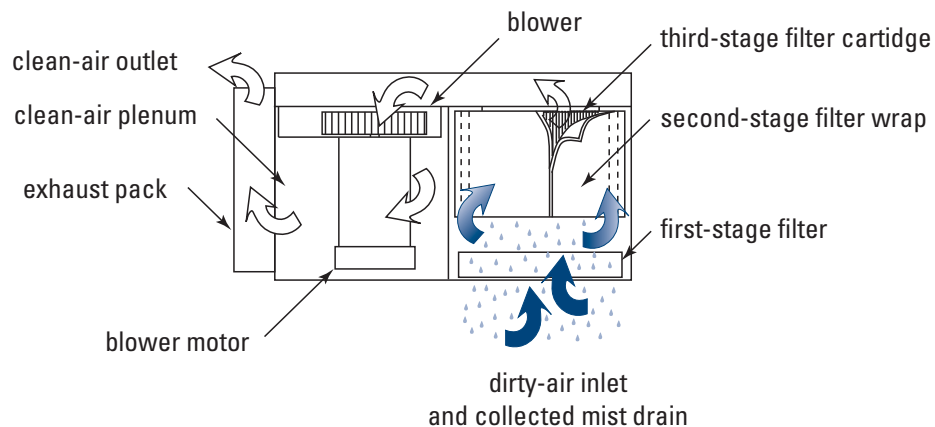

## DRYFLO FILTER MEDIA

Dryflo® filter media is made from proprietary synthetic media incorporating both small and large fibers for optimum filtration. The smaller fibers provide increased filtration efficiency; after mist is captured and coalesced, the larger fibers allow the oil to drain from the filter. The media also incorporates a proprietary corrugation method which maintains uniform airflow and lower pressure while the media is saturated with oil.

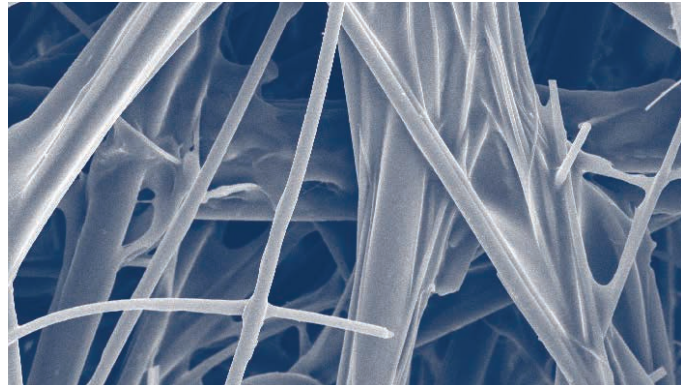

Dryflo Filter Media

## HIGH PERFORMANCE THREE-STAGE FILTRATION: IMPROVES COLLECTION EFFICIENCY AT EVERY STAGE

### FIRST-STAGE

A prefilter that removes larger mist droplets, metal dust and swarf captured by the collector. Wire mesh thin screen and polypropylene mesh are available.

### SECOND STAGE

A three-layer wrap of synthetic high-loft material collects small mist drops into larger oil droplets, which drain out of the mist collector.

### THIRD-STAGE

Collects, coalesces and drains the finer mist droplets generated by metalworking applications. Along with vertically oriented pleats, the third-stage filter cartridge incorporates the Pleatloc™ media spacing system, which enhances drainage and provides a lower pressure drop, higher filtration efficiency and less re-entrainment of collected mist.

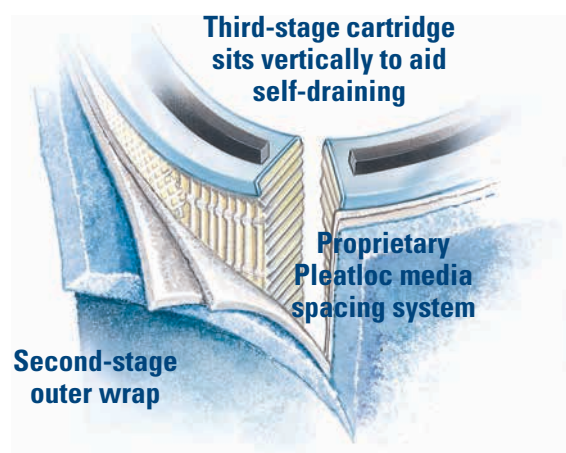

## LONG-LASTING EFFICIENCY

The Dryflo® cartridge is a proven, highly efficient mist filter that actually increases efficiency over time when collecting soluble oil or synthetic fluid. In tests conducted by the University of North Carolina (UNC), the Dryflo was shown to offer increased efficiency over time, resulting in longer HEPA filter life and reduced HEPA filter replacement costs.

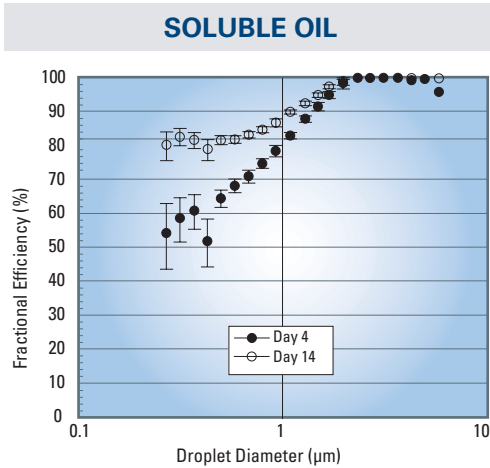

Efficiency vs. droplet diameter for Dryflo® cartridge and wrap assembly on days 4 and 14 with soluble oil at an airflow of 1000 cfm (28.3 m<sup>3</sup>/m). Error bars represent 95% confidence intervals.

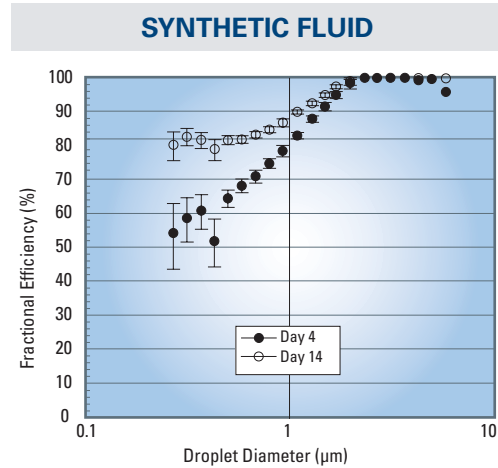

Efficiency vs. droplet diameter for Dryflo® cartridge and wrap assembly on days 4 and 14 with synthetic fluid at an airflow of 1000 cfm (28.3 m<sup>3</sup>/m). Error bars represent 95% confidence intervals.

## GAUGING EFFICIENCY

Using UNC’s protocol for evaluating the cartridge efficiency, Dryflo® mist collectors with HEPA final filter are a reliable, high performance filtration solution. To prolong HEPA filter life, the upstream filter stages must also be highly efficient. HEPA life depends on the cumulative loading it receives, which in turn, depends on the performance of the upstream collection stages.

Evaluating efficiency as a function of droplet diameter and pressure drop over 14 days, UNC protocol determines the size distribution of droplets generated during a variety of wet machining operations. Droplet sizes ranging from 1.8 micron to 3.2 micron were tested to determine the average efficiency of Dryflo® collectors on soluble oil and synthetic fluid.

Average Efficiency of Dryflo® on Soluble Oil and Synthetic Fluid		
Droplet Size	Dryflo® Collector with HEPA	Dryflo® Collector without HEPA
1.8 micron	100%	98%
3.2 micron	100%	100%

Note: The data provided in this report is a result of tests performed using the UNC protocol. When comparing these results with other products, be sure the data being compared is derived by the same methodology.

## DIMENSIONS & SPECIFICATIONS

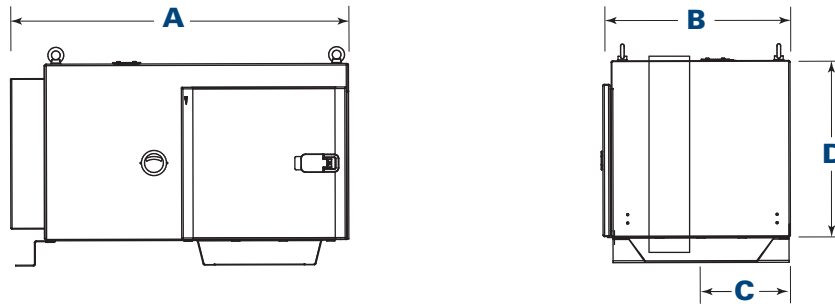

Models	Nominal Airflow		No. of Filters	Filter Area		Motor (hp)	Shipping Weight		Dimensions								Sound Level db(A)
	cfm	m³/h		ft²	m²		lb	kg	A		B		C		D		
									in	mm	in	mm	in	mm	in	mm	
DMC-MMA	390	662	1	41	12.5	0.75	85	38.6	30.3	769.6	16.0	406.4	8.0	203.2	15.8	401.3	65
DMC-MMB	800	1359	1	82	25.0	1.5	165	74.8	39.1	993.1	20.7	525.8	10.4	264.2	20.8	528.3	69

## STANDARD FEATURES & AVAILABLE OPTIONS

COLLECTOR DESIGN	STD	OPT	CARTRIDGE FILTERS (CONT'D)	STD	OPT
Mild Steel Construction	X		Dryflo® Cartridge Filter with Wrap	X	
Inlet Gasket		X	Fourth-Stage HEPA Filter		X
Inlet Collar		X	Fourth-Stage 95% DOP Filter		X
Inlet Hopper with Legs		X	<b>PAINT SYSTEM</b>		
Inlet Hopper with Vibration Isolators		X	Prime Coated Interior	X	
Inlet Hopper with Flex-Duct		X	Textured Multi-Coat Paint Finish with 2,000-Hour Salt Spray Performance	X	
Inlet Hopper with Impact Separator		X	Premium Duty Finish		X
Machine Mount	X		Custom Colors, Materials, and Finishes		X
Ceiling Mount		X	<b>ELECTRICAL CONTROLS, GAUGES &amp; ENCLOSURES</b>		
Collector Stand or Cart		X	Minihelic** Pressure Gauge	X	
Junction Box		X	Manual Motor Starter		X
Drain Collection Container		X	Type 12 (NEMA & UL) Motor Starter		X
<b>Cartridge Filters</b>			Remote Start/Stop		X
First-Stage Wire Mesh	X		Machine Tool Interlock		X
Variety of Other Prefilters		X	Mounted and Wired Motor Starters		X
High Efficiency First-Stage		X	<b>WARRANTY</b>		
			10-Year Warranty	X	

\*Minihelic is a registered trademark of Dwyer Instruments, Inc.

### Important Notice

Many factors beyond the control of Donaldson can affect the use and performance of Donaldson products in a particular application, including the conditions under which the product is used. Since these factors are uniquely within the user's knowledge and control, it is essential the user evaluate the products to determine whether the product is fit for the particular purpose and suitable for the user's application. All products, product specifications, availability and data are subject to change without notice, and may vary by region or country.



8001 Rue Larrey, Anjou, QC, Canada, H1J 2L4  
 514-273-4331 • info@capt-air.com • www.capt-air.com