



# Rotary Valve VDL-HTHB (Heat resistant)

PRODUCT CODE: 59902

## APPLICATIONS

- Rotary airlock for dust collectors and cyclones
- Feeder valve for screw conveyors, scales, dryers and coolers
- Rotary valve is suitable for ambient temperature up to 104°F/40°C
- Suitable for product temperatures up to 572°F/300°C
- Differential pressures up to 40" WG

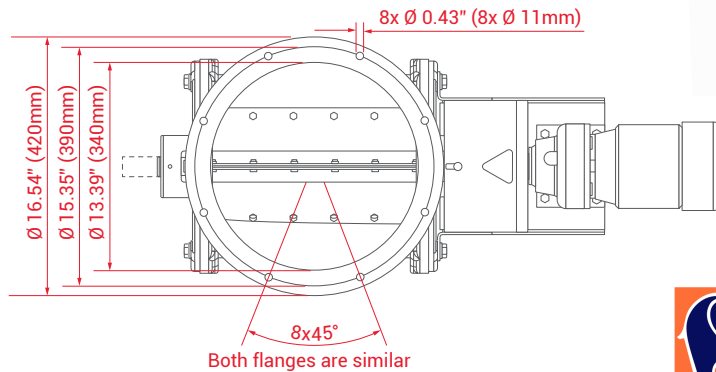

**CAPT-AIR®**

8001 Rue Larrey, Anjou, QC, Canada, H1J 2L4  
514-273-4331 • info@capt-air.com • www.capt-air.com

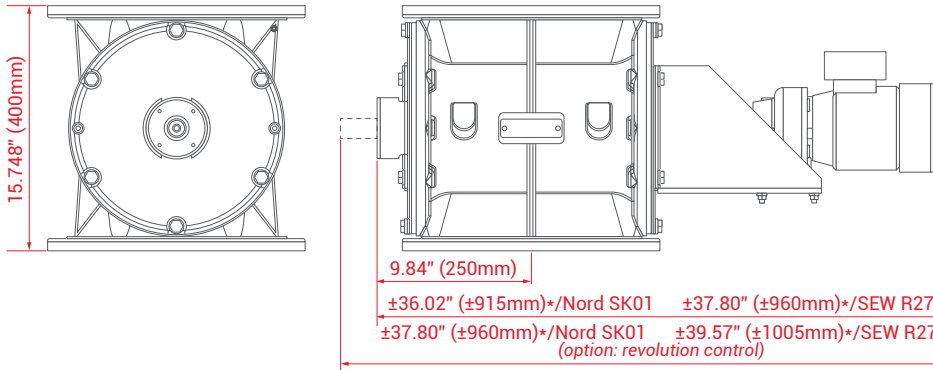

\* Length varies dependent on motor selection

	VDL-HTHB-250	VDL-HTHB-350
Body and covers	Cast iron GG25	
Inlet and outlet	10" / 250 mm	14" / 350 mm
Rotor construction	Open, with 6 chambers	
Drive unit	Direct, with chain coupling and gearmotor HTHB 250 : 0.33 HP (15 RPM) - 0.50 HP (30 RPM)	Direct, with chain coupling and gearmotor HTHB 350 : 0.50 HP (15 RPM) - 1.00 HP (30 RPM)
Finishing	<ul style="list-style-type: none"> <li>■ Inlet and outlet painted in heat resistant, silver paint</li> <li>■ Body, covers and motor console painted in heat resistant, silver paint</li> </ul>	
Sealing	<ul style="list-style-type: none"> <li>■ Bronze bush</li> <li>■ Rotor with 6 chambers : Bronze bush + heat resistant sealing + heat resistant feltring</li> </ul>	
Bearings	Slide bearings with PTFE coating	
Max. operating pressure	40" w.g. / 5.000 Pa	
Temperature	5°F up to 572°F / -15°C up to 300°C	
Capacity (100% filling)	0,23 ft <sup>3</sup> (7 liters) / rev	0,70 ft <sup>3</sup> (20 liters) / rev



ROTORS



INSULATION