

Donaldson®  
Torit®

**DOWNFLO® OVAL  
DUST COLLECTORS**

**ULTRA-WEB®**  
High Efficiency Nanofiber Filters Built to Last



## A FAMILY OF OVER-ACHIEVERS

The high performance Downflo® Oval (DFO) family of over-achieving dust collectors provides up to 25 percent more filtration capacity than other same-sized cartridge collectors. Powered by proprietary Ultra-Web® nanofiber filtration technology, DFO delivers cleaner air, up to two times longer filter life, and greater cost savings.

The DFO advantage is found in the collector's proprietary design and components. The combination of a new cabinet design that greatly lowers cabinet velocities, proprietary Extra-Life™ cleaning technology, and proven Ultra-Web nanofiber filters allows more airflow through the collector without increasing the size of the footprint or damaging the filters.

A smaller collector helps lower the initial purchase price, reduces filter replacement costs and opens up valuable manufacturing floor space.

### DFO offers:

- **Lower initial cost per cubic foot of air per minute (cfm)**
- **Higher efficiency—cleaner air**
- **Lower pressure drop—greater energy savings**
- **Fewer filter changeouts**
- **Reduced filter disposal cost**
- **Easy system setup**
- **Less maintenance**
- **10-year warranty**



DFO 3-18

**25%**  
**MORE CAPACITY**

## OUTPERFORMS ALL OTHER COLLECTORS

DFO collectors offer some strong benefits that distinguish them from all other collectors available in the market today.

- **EASY TO USE**  
Quick-release handles provide easy cover removal and faster filter access.
- **COMPACT**  
Smaller footprints for applications that require maximum cleaning efficiency in even smaller spaces.
- **POWERFUL**  
DFO collectors provide 25 percent more capacity than same-sized dust collectors.
- **COST EFFECTIVE**  
The proprietary ExtraLife™ Filter Cleaning System averages up to 30 percent increase in pulse cleaning energy for unmatched cleaning ability.
- **INNOVATIVE**  
Unique oval-shaped Ultra-Web® cartridge filters provide the longest filter life and highest filtration efficiency— which lowers cost.



DFO 2-4



DFO 3-3

## SIZES &amp; OPERATIONS

**DFO Models 1-1, 2-2 and 3-3**

- Incorporate several exclusive and unique features
- Completely self-contained, “plug-and-play” type units
- Packaged with power pack, controls, silencer, damper, dust container and more
- Remarkably quiet operation
- Exceptionally compact design
- Easily movable through standard aisles and doorways

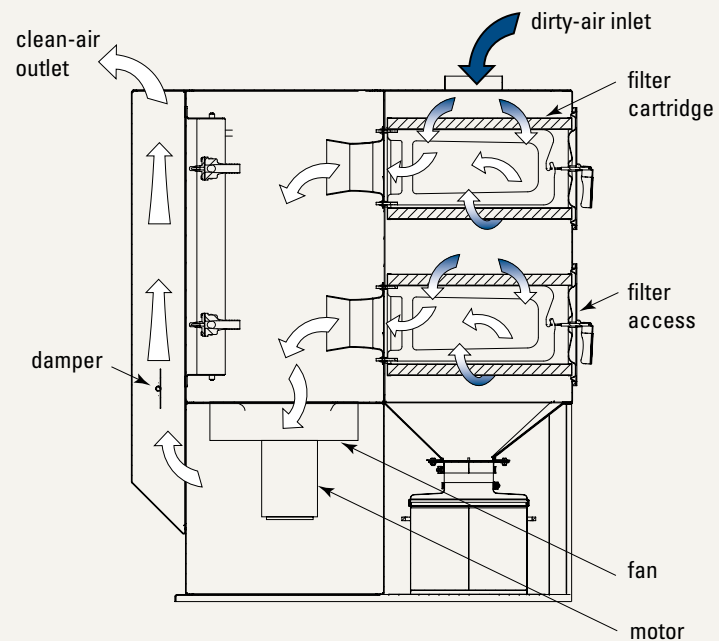
**NORMAL OPERATIONS  
FOR MODELS  
1-1, 2-2 and 3-3**

DFO 1-1

## SIZES &amp; OPERATIONS

**NORMAL OPERATIONS  
FOR MODELS  
2-4 through 4-128**

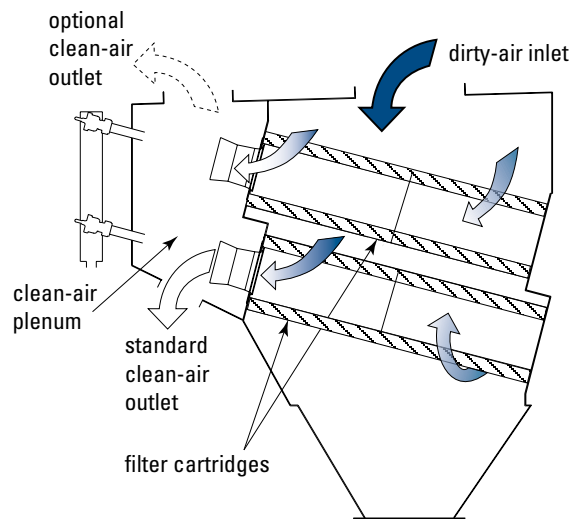

**DFO Models 2-4 to 4-128**

- **23 standard model sizes**
- **Customized sizes available**
- **Many options and accessories**
- **Exceptionally compact design**
- **Significant energy savings**



**SIMPLY  
THE BEST**

CARTRIDGE COLLECTORS AVAILABLE

DFO TECHNOLOGY UNFOLDS

PROPRIETARY TECHNOLOGY THAT PERFORMS

The remarkable story of DFO begins with the oval cartridge and Ultra-Web media technology. Proven and proprietary Ultra-Web technology delivers longer filter life, cleaner air and greater cost savings than other types of cartridge filter media. Made with an electrospinning process that produces a very fine, continuous fiber of 0.2-0.3 micron in diameter, Ultra-Web nanofibers form a permanent web-like net with very fine interfiber spaces that trap dust on the surface of the media.



**Nanofiber Media**  
(600x)

Nanofiber surface loading technology is available in all Ultra-Web and Fibra-Web cartridge filters.



**Commodity Filter Media**  
(600x)

Conventional media has spaces of up to 60 µm between fibers, allowing dust to become deeply embedded.

DFO FILTER MEDIA PLEATS

The innovation of shorter and stiffer filter pleats helps minimize dust entrapment and simplify filter cleaning. By reducing the height of the filter pleats from the standard 2 inches to 1.5 inches, the pleat wall is less likely to collapse or bend, which can encapsulate dust and prevent its expulsion.



DOWNFLO OVAL FILTER



STANDARD FILTER

## MORE AIRFLOW, LESS FILTER MEDIA

### UNIQUE OVAL SHAPE CONTRIBUTES TO HIGHER AIRFLOW CAPACITY

The Downflo Oval filter design is a reflection of Donaldson Torit's commitment to technical research and development. High performance oval-shaped filters handle up to 25 percent more airflow without increasing velocities, which can cause filter abrasion. Sophisticated FLUENT®\* Airflow Modeling Software revealed that oval-shaped cartridge filters have fewer areas of high velocity, resulting in a lower potential for media abrasion and increased filter life.

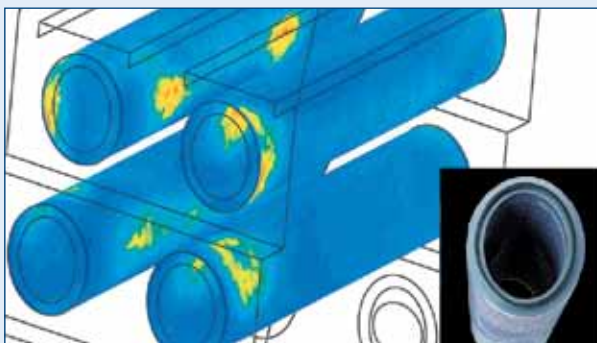

DOWNFLO OVAL COLLECTOR: 9145 CFM

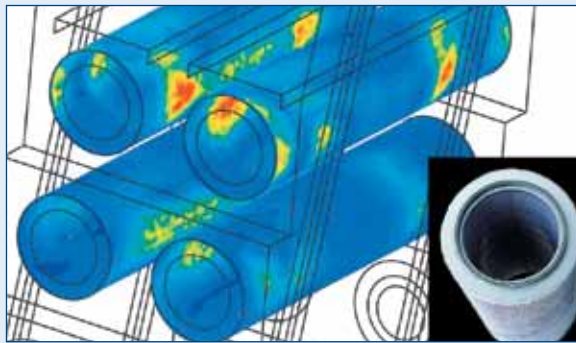

STANDARD COLLECTOR: 7315 CFM

### AIRFLOW BREAKTHROUGHS LEAD TO HIGHER FILTRATION EFFICIENCY

Sophisticated computer modeling for fluid dynamics, structural mechanics and acoustics puts DFO models 1-1, 2-2, and 3-3 in a technical class all their own. The illustration below (left) shows how FLUENT Flow Modeling Software enhanced the uniform air velocity distribution through model DFO 3-3. ANSYS®\* Structure Analysis Software shown below (right) demonstrates lowest stress levels and deflections for model DFO 3-3 under typical operating pressures.

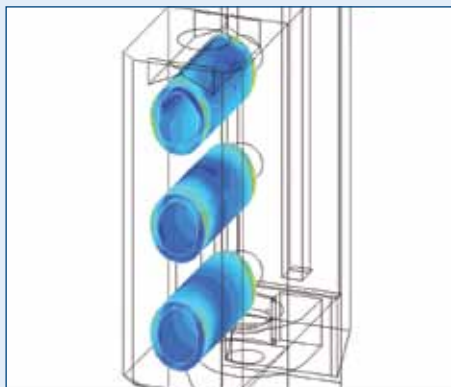

DFO 3-3 AIR VELOCITY DISTRIBUTION



DFO 3-3 STRESS AND DEFLECTIONS MODEL

\* FLUENT is a registered trademark of Fluent, Inc.; ANSYS is a registered trademark of ANSYS, Inc.

BETTER FILTRATION, PROLONGED FILTER LIFE

CONVEX SIDE WALLS

Technical discoveries improve filtration performance and prolonged filter life. A new cabinet design with convex side walls streamlines the airflow path and increases the cabinet's cross-sectional area. The convex side walls provide more space between filters, lower cabinet velocities and reduce the potential for media abrasion.

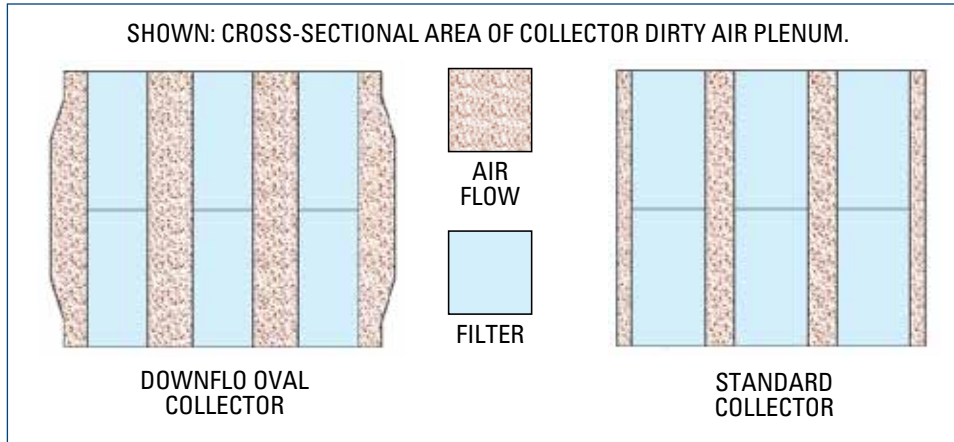

CROSS-SECTIONAL AREAS

PULSE CLEANING TECHNOLOGY

ExtraLife Filter Cleaning System uses proprietary, computer-modeled pulse cleaning technology to easily “pulse off” dust from the surface of the filter, improving filtration efficiency and prolonging filter life. The red lines in the illustration show the increased pressure at the front of the Downflo filter generated by the ExtraLife system. The blue line shows the pulse signature of a standard cartridge collector.

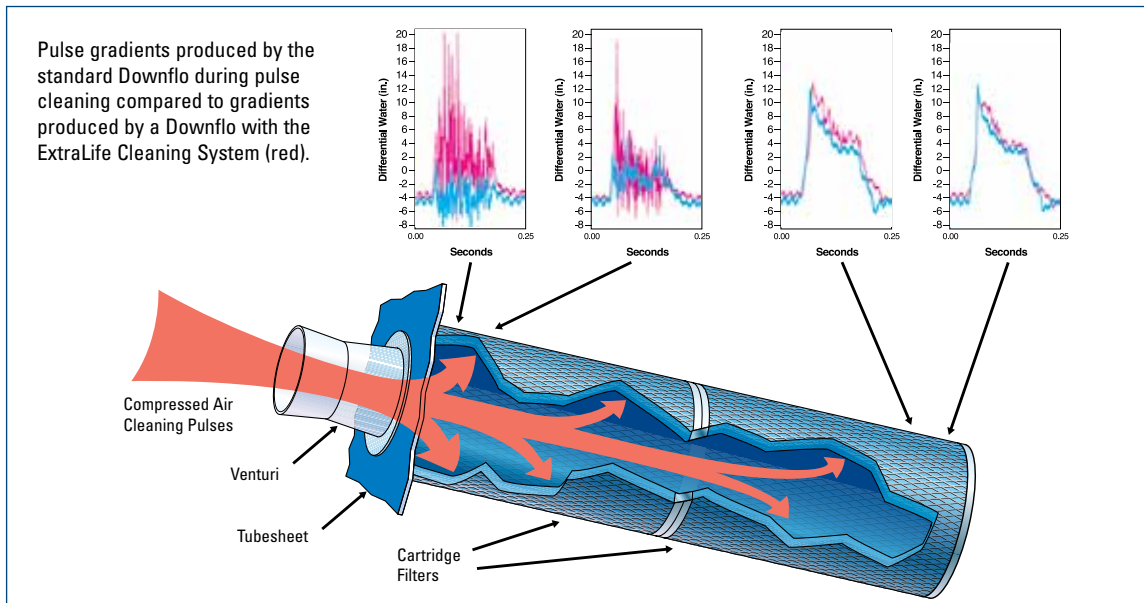

DOWNFLO PULSE PRESSURE GRADIENTS



## FILTER CHANGES AND DISCHARGE MAINTENANCE

### EASY MAINTENANCE

With the new design of the DFO's quick-release access handles, filter removal and maintenance is extremely fast with one simple movement of the clamp.



### BAG-IN/BAG-OUT ARRANGEMENTS

Improve filter changeouts and hopper discharge maintenance, help minimize worker exposure to potentially harmful dusts, and reduce exposure of contaminants to the atmosphere.

- Porthole covers protect changeout bags and provide a clean appearance.
- Heavy-duty plastic bags hold filters and function as gloves during the changeout procedure.
- Filters are disposed of in a sealed bag.
- Bag-in/Bag-Out drum arrangement is safely held in place through drum latches and hose clamps.

## OPERATING ADVANTAGES &amp; CONDITIONS

DFO MODELS	1-1	2-2	3-3	2-4 through 4-128
Horsepower (HP)	1.5	3	5	**
Sound Level dB(A)*	68	68	70	**
External Static Pressure ("wg)	***	***	***	**
Housing Construction (gauge)	12	12	12	10 (collector) 7 (tubesheet)
Housing Rating (inches H <sub>2</sub> O)	-20	-20	-20	-20
Wind Load Rating (mph)	—	—	—	100
Seismic Rating (zone)	4	4	4	4
Compressed Air Required (psig)	60	60	60	2-4, 3-6: 60 2-8 and up: 90-100
Electrical Power Valves/Controls	120 VAC, 50/60 Hz	120 VAC, 50/60 Hz	120 VAC, 50/60 Hz	120 VAC, 50/60 Hz

\* Sound measurements were taken in a hemianechoic chamber and under free field conditions and do not reflect the influences of actual operating environments. Standard sound pressure levels were taken at an operator position of 1.5 m high and 1 m from source.

\*\* Provided through Donaldson Torit fan program.

\*\*\* See system performance curves on page 9.



## ADDRESSING SAFETY CONCEPTS

Donaldson Torit manufactures or partners with experts to provide solutions for critical processes where harmful particulate must be controlled.

- Explosion Relief Panels  
(with or without weather domes)
- Suppression Systems
- Reinforced Housing Construction

SYSTEM CURVES FOR DFO MODELS 1-1, 2-2 and 3-3

POWERFUL PERFORMANCE

Unlike other technologies that require upgrades for more demanding applications, each DFO 1-1, 2-2 and 3-3 footprint comes standard with a unique high performance power pack. The system performance graphs below show the fan performance with clean filters. The curve indicates available external static pressure to the unit.

**DFO 1-1 1.5HP 60Hz with 6 in. inlet duct (clean filter)**

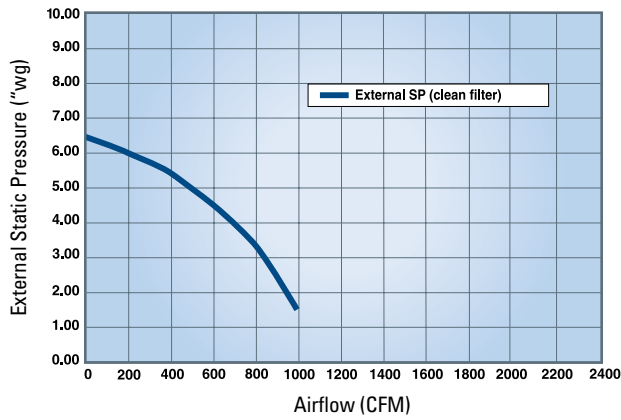

**DFO 1-1 1.1kW 50Hz with 6 in. inlet duct (clean filter)**

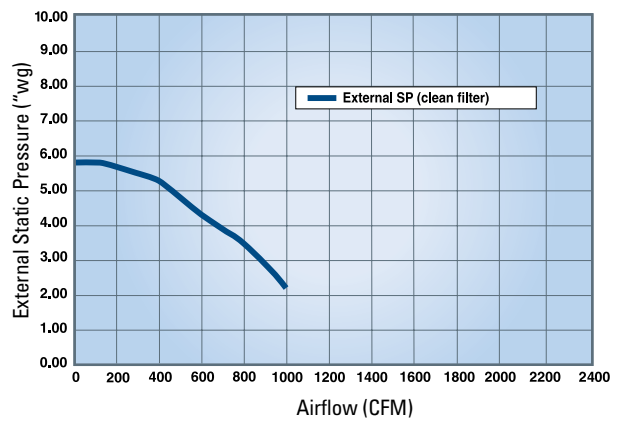

**DFO 2-2 3HP 60Hz with 8 in. inlet duct (clean filters)**

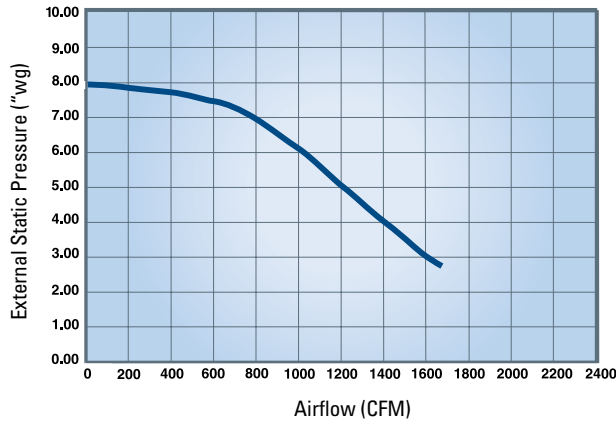

**DFO 2-2 2.2kW 50Hz with 8 in. inlet duct (clean filters)**

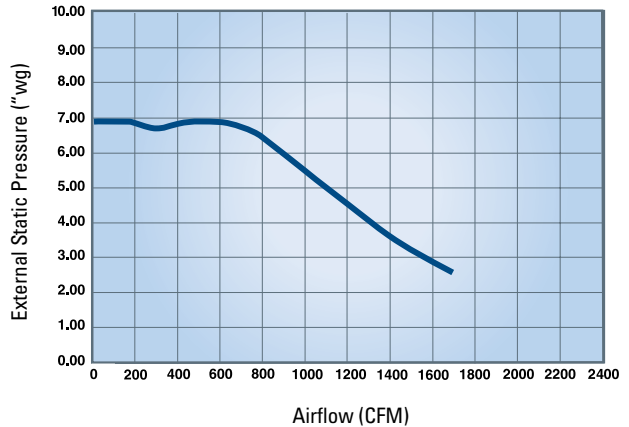

**DFO 3-3 5HP 60Hz with 9 in. inlet duct (clean filters)**

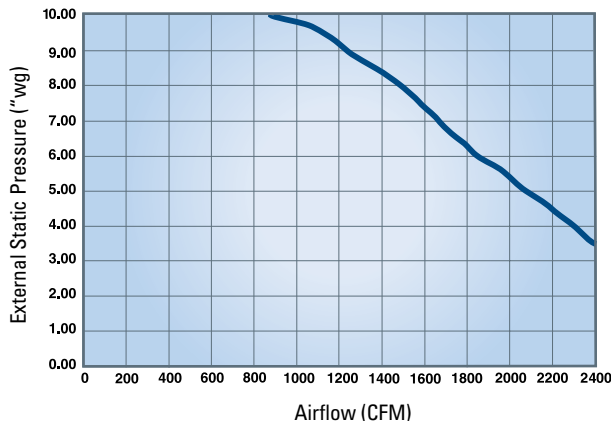

**DFO 3-3 4.0kW 50Hz with 9 in. inlet duct (clean filters)**

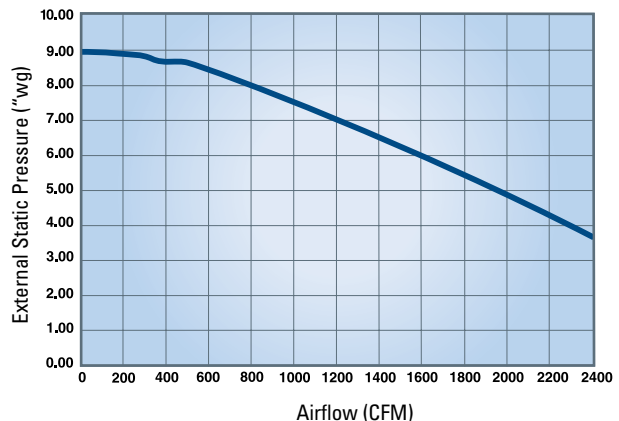

DIMENSIONS & SPECIFICATIONS

BASE MODULES  
1-1, 2-2 & 3-3

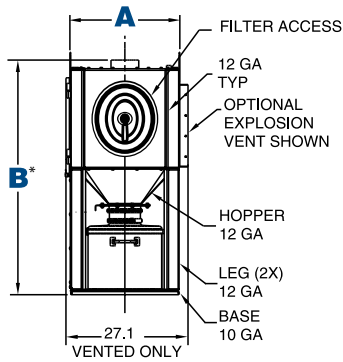

Front View  
DFO 1-1

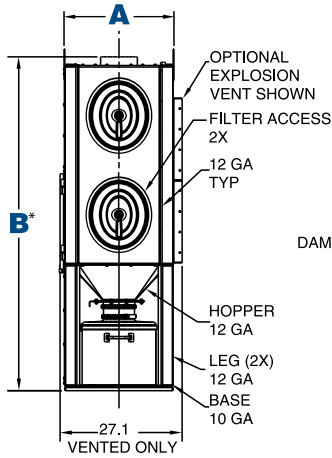

Front View  
DFO 2-2

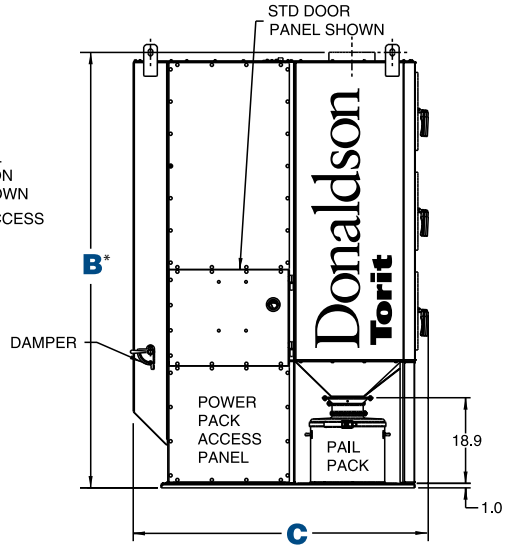

Left Side View  
DFO 3-3

\* Top of inlets.

BASE MODULES  
2-4 through 4-128

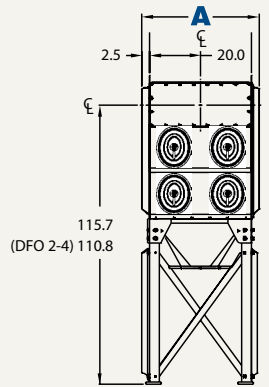

Front View  
DFO 2-Models

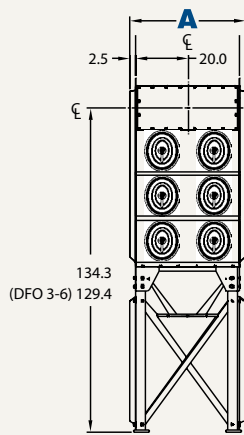

Front View  
DFO 3-Models

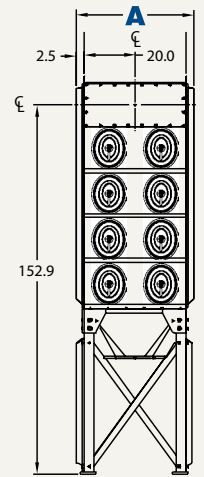

Front View  
DFO 4-Models

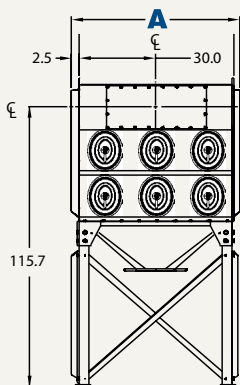

Front View DFO 2-12  
(3-Wide Models)

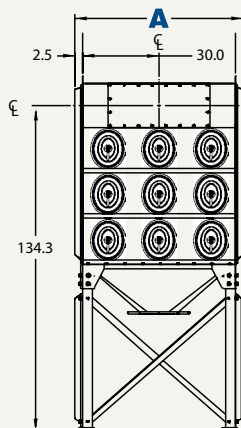

Front View DFO 3-18  
(3-Wide Models)

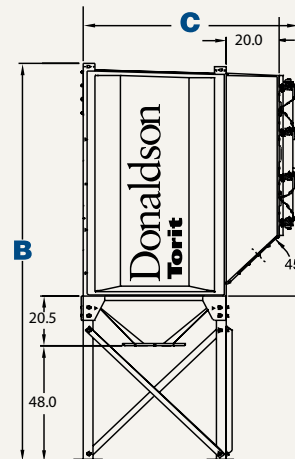

Right Side View  
All Models

## DIMENSIONS &amp; SPECIFICATIONS

DFO Model*	Nominal Airflow Range** (cfm)	No. of Filters	Ultra-Web Filter Area (ft <sup>2</sup> )	No. of Valves	Approx. Shipping Weight (lbs)***	Dimensions (inches)		
						A	B	C
1-1	100-800	1	190	1	800	30.0	52.0	65.0
2-2	200-1,600	2	380	2	1,000	30.0	74.0	65.0
3-3	300-2,400	3	570	3	1,300	30.0	96.0	65.0
2-4	380-3,190	4	760	4	1,100	45.0	118.8	62.0
2-8	760-6,380	8	1,520	4	1,600	45.0	127.8	84.0
2-12	1,140-9,580	12	2,280	6	2,100	65.0	127.8	84.0
2-16	1,520-12,770	16	3,040	8	3,100	85.0	127.8	84.0
2-24	2,280-19,150	24	4,560	12	4,200	125.0	127.8	84.0
2-36	3,420-28,730	36	6,840	18	6,300	185.0	127.8	84.0
3-6	570-4,790	6	1,140	6	1,400	45.0	137.4	62.0
3-10	950-7,980	10	1,900	5	1,900	45.0	146.5	85.3
3-12	1,140-9,580	12	2,280	6	2,000	45.0	146.5	85.3
3-18	1,710-14,370	18	3,420	9	2,800	65.0	146.5	85.3
3-24	2,280-19,150	24	4,560	12	3,300	85.0	146.5	85.3
3-36	3,420-28,730	36	6,840	18	6,100	125.0	146.5	85.3
3-48	4,560-38,300	48	9,120	24	8,100	165.0	146.5	85.3
3-60	5,700-47,880	60	11,400	30	10,100	205.0	146.5	85.3
3-72	6,840-57,460	72	13,680	36	12,100	245.0	146.5	85.3
4-16	1,520-12,770	16	3,040	8	2,400	45.0	165.1	85.3
4-32	3,040-25,540	32	6,080	16	4,200	85.0	165.1	85.3
4-48	4,560-38,300	48	9,120	24	7,400	125.0	165.1	85.3
4-64	6,080-51,070	64	12,160	32	9,100	165.0	165.1	85.3
4-80	7,600-63,840	80	15,200	40	11,000	205.0	165.1	85.3
4-96	9,120-76,600	96	18,240	48	12,600	245.0	165.1	85.3
4-112	10,640-89,380	112	21,280	56	14,500	285.0	165.1	85.3
4-128	12,160-102,150	128	24,320	64	16,100	325.0	165.1	85.3

\* The first number indicates number of filter rows, and the second number indicates number of cartridges.

\*\* Based on clean filters.

\*\*\* Without accessories or optional equipment.

PROVEN PERFORMANCE ON HUNDREDS OF APPLICATIONS



**DFO 3-6**  
on sawing of  
high pressure  
hydraulic hose



**DFO 4-112**  
on titanium grinding

**DFO 2-4**  
on fiberglass routing & cutting



**DFO 2-2**  
on paint pigment dust



**DFO 4-48**  
on metal grinding

## STANDARD FEATURES &amp; AVAILABLE OPTIONS

## DFO 1-1, 2-2, 3-3

Collector Design	Std	Opt
Mild Steel Construction	X	
Integral High Performance Power Packs	X	
Ledge-Free Hopper	X	
Inlet	X	
Sprinkler Taps	X	
ExtraLife™ Filter Cleaning System	X	
Quick-Removal Access Covers	X	
Integral Exhaust Silencer	X	
Airflow Damper	X	
Stainless Steel Construction		X
Explosion Protected Models		X
High Static Power Packs		X
Inlet Damper		X
Abrasion Resistant (AR) Inlet		X
Sprinkler Heads		X
Extraction Arms (7', 10', 14')		X
Caster Packs		X
Bag-Out Kit (Filter & Discharge)		X
Bag-In/Bag-Out Kit (Filter & Discharge)		X
<b>Cartridge Filters</b>		
Ultra-Web® (MERV* 13)	X	
Fibra-Web® (MERV 14); Ultra-Tek® (MERV 12); Thermo-Tek® (MERV 12); Torit-Text™ (MERV 16)		X
HEPA/ASHRAE Afterfilters		X
<b>Paint System</b>		
Electrostatically applied powder coat TGIC polyester texture finish (2-mil dry film thickness) inside and out. Paint system passed 350-hr. salt spray test.	X	
Custom Color		X
Hostile Environment Coating		X
Epoxy Coating		X
<b>Hopper Discharge</b>		
10-Gallon Pail Pack	X	
10-Gallon Pail Pack with Sealer Gear		X
25-Gallon Dust Container		X
<b>Electrical Controls, Gauges &amp; Enclosures</b>		
Minihelic® Gauge	X	
Manual or Automated Downtime Cleaning	X	
Solenoid Enclosure in NEMA 12	X	
Continuous On-Demand Delta P Control		X
Solenoid Enclosure NEMA 9		X
Starter Controls		X
<b>Warranty</b>		
10-Year Warranty	X	

\* The Minimum Efficiency Reporting Value (MERV) of this filter cartridge has been determined through independent laboratory testing using ASHRAE 52.2 (2007) test standards. The MERV rating was determined at a face velocity of 118 feet per minute and loading up to four inches water gauge. Actual efficiency of any filter cartridge will vary according to the specific application parameters. Dust concentration, airflow, particle characteristics, and pulse cleaning methods all affect filtration efficiency.

\*\* Minihelic, Magnehelic and Photohelic are registered trademarks of Dwyer Instruments, Inc.

## DFO 2-4 through 4-128

Collector Design	Std	Opt
Mild Steel Construction	X	
ExtraLife™ Filter Cleaning System	X	
Quick-Removal Access Covers	X	
Inlets	X	
Ledge-Free Hopper	X	
Sprinkler Taps	X	
Stainless Steel Construction		X
High Temperature Construction		X
Explosion Protected Models		X
Direct Drive Fans		X
Chamber and Exhaust Silencers		X
Abrasion Resistant (AR) Inlet		X
Air Management Modules		X
Extended Dirty Air Plenum		X
Steep-Sided Hopper		X
2-Mod Hopper		X
Sprinkler Heads		X
Service Platform (OSHA compliant)		X
Damper Pack		X
Drum Sentry™ Drum-Full Indicator		X
Lined Clean Air Plenum		X
Bag-Out Kit (Filter & Discharge)		X
Bag-In/Bag-Out Kit (Filter & Discharge)		X
<b>Cartridge Filters</b>		
Ultra-Web® (MERV* 13)	X	
Fibra-Web® (MERV 14); Ultra-Tek® (MERV 12); Thermo-Tek® (MERV 12); Torit-Text™ (MERV 16)		X
HEPA/ASHRAE Afterfilters		X
<b>Paint System</b>		
Prime Coated Interior	X	
Acrylic urethane finish over alkyd enamel primer. Paint system passes a 350-hr. salt spray test.	X	
Custom Color		X
Hostile Environment Coating		X
Epoxy Coating		X
<b>Hopper Discharge</b>		
Drum Cover and Hose		X
Slide Gates		X
Rotary Valves and Transitions		X
Screw Conveyors		X
<b>Electrical Controls, Gauges &amp; Enclosures</b>		
Control Box w/Timer in NEMA 4 Enclosure	X	
Magnehelic® Gauge Controls	X	
Delta P Control, Delta P Plus Control		X
Dustronix™ Control Assembly		X
Custom Panels		X
Photohelic® Gauge Standard and Weatherproof		X
Basic Cold Climate Kit		X
Heavy-Duty Cold Climate Kit		X
Solenoid Enclosure (NEMA 7 & 9)		X
<b>Warranty</b>		
10-Year Warranty	X	



## GLOBAL SUPPORT



- Facilities in 37 countries
- 40 manufacturing plants and 14 distribution centers
- Sales offices worldwide

## LEADING TECHNOLOGY



- Over 1,000 engineers and scientists worldwide
- Broad range of innovative collectors and filters
- 100s of filter media formulations

## EXPERIENCE & SERVICE



- Technical expertise and support
- Ready-to-ship filters and parts within 24 hours
- 1,000,000+ dust, fume, and mist collectors installed



**Call Donaldson Torit  
to get Cleaner Air today  
800-365-1331  
donaldson.com**